

ORIGINAL INSTRUCTIONS

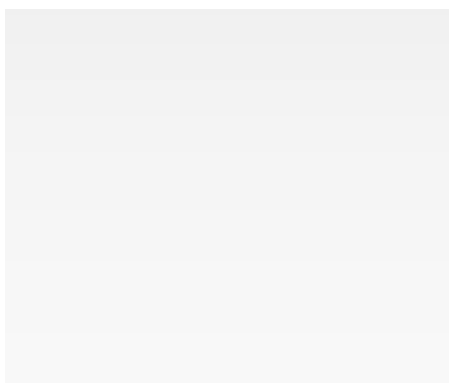

**INSTALLATION, USE AND  
MAINTENANCE MANUAL**



COMPANY WITH  
QUALITY SYSTEM  
CERTIFIED BY DNV GL  
= ISO 9001 =

2020 – **Juop** – Azzano Decimo (PN)

Reproduction, electronic storage and dissemination, even partial, are prohibited.

Juop reserves the right to modify the products described in this manual without prior notice.

Any product names mentioned herein are the trademarks of their respective owners.

## Contents

<b>1. General warnings</b>	pag.	4	SPARE PART DATA SHEET – PN 23-33 DIRECT TRANSM. - HYD	23
1.1 Introduction		4	SPARE PART DATA SHEET – PN 23-33 WITH GEARBOX	25
1.2 Spare part request		4	SPARE PART DATA SHEET – PN 45-58-84 DIRECT TRANSM. - HYD	27
1.3 Warranty terms and conditions		4	SPARE PART DATA SHEET – PN 45-58-84 WITH GEARBOX	29
<b>2. Technical data</b>	pag.	5	SPARE PART DATA SHEET – PN 106 DIRECT TRANSM. - HYD	31
2.1 Dimensions and arrangements		6	SPARE PART DATA SHEET – PN 106 WITH GEARBOX	33
2.2 Performances		7	SPARE PART DATA SHEET – PN 106 WITH GEARBOX 1000 RPM	35
2.3 Usage limitations		8	SPARE PART DATA SHEET – PN ACCESSORIES	37
2.4 Sound pressure level		8		
2.5 Lubrication		8		
<b>3. Safety and accident prevention</b>	pag.	9		
3.1 General recommendations		9		
3.2 Intended use		9		
3.3 Conveyed fluids		9		
<b>4. Installation</b>	pag.	10		
4.1 Compulsory accessories		10		
4.2 Checking upon receipt		10		
4.3 Storing in the warehouse		10		
4.4 Handling and installation		10		
4.5 Mounting		10		
4.6 Vacuum – Pressure Line		11		
4.7 Vacuum-pressure inverter: Remote control actuators		12		
4.8 Pump mounting – Drive connection		13		
<b>5. Start up</b>	pag.	15		
5.1 Pump starting-up		15		
5.2 Precautions when starting the system		15		
<b>6. Maintenance</b>	pag.	16		
6.1 Ordinary maintenance		16		
6.2 Extraordinary maintenance		18		
<b>7. Malfunctions: troubleshooting</b>	pag.	21		
<b>8. Scarapping</b>	pag.	21		
<b>9. Accessories</b>	pag.	22		

# 1. General warnings

## 1.1. Introduction

- This booklet contains the necessary instructions for a correct installation, running, use and maintenance of the pump, as well as some practical suggestions for a safe operating.
- The knowledge of the following pages will grant a long and trouble-free operation of the pump.
- Following the instructions below contributes to limiting pump repair expenses by extending its duration, as well as preventing hazardous situations, thereby increasing its reliability.
- If the pump is driven by an hydraulic motor please refer to manufacturer's specific manual.
- It is recommended to:
  - Read, understand and apply carefully the instructions before running the pump.
  - Keep the booklet at hand and have it known to all operators.
- Below is a brief description of the symbols used in this manual.



If these safety rules are not respected, operators can be injured and the pump or oilers damaged remarkably.



If these safety rules are not respected, the pump or system can be damaged.



Suggestions for an environment friendly use of the pump.



Useful information for an easy usage and maintenance of the pump.

- The graphic representations and photographs contained in this manual are there to illustrate the product in the parts that make it up and in specific operating phases. Though the model shown in the manual may differ from the one purchased, the operating principle at the base of the illustrated operating phase is the same.
- Every PN pump has to be fitted with its own tag reporting the following data: Model, Serial number, Year, Max speed, Max pressure.

MADE IN ITALY <small>Jurop S.p.A. - Via Crosera, 50 - 33082 Azzano Decimo - PN (ITALY)</small>		
MOD.		
SERIAL No.		
YEAR		
MAX PRESSURE	(bar)	
MAX SPEED	(r.p.m.)	

Pic. 1.1

## 1.2. Spare part request

- Use only **genuine spare parts** for maintenance and repairs. To order spare parts, provide the following details:

EXAMPLE:

a) The model of the pump (see pump tag)	PN 45
b) The serial number of the pump (see pump tag)	J90001
c) A description of the parts (see parts list)	VANE
d) The quantity (see parts list)	4
e) The code number of the part (see parts list)	16016 008 00

## 1.3. Warranty terms and conditions

- Compliance with the installation, use and maintenance instructions provided by this manual **is crucial for the recognition of warranty** against defective parts.

## 2. Technical data

- The **PN Series** decompressors are designed for agricultural use (tanker outfitting) but can also be used in industrial applications (lorry outfitting).
- The technology applied is that of rotary vane pumps: the rotor, equipped with moving vanes, rotates eccentrically inside the pump body. The vanes are kept in contact with the internal surface of the body by the centrifugal force. Between the vanes and the body there is always an oil film that acts as a sealing and lubricating element.
- Lubrication is forced with a gear pump and adjustable oilers; the shaped pipes are made of copper, while the intake and exhaust conveyors are made of aluminium. The oil tank is built into all models; on request, the PN 106 model can be supplied with a side oil tank and automatic lubrication system with a volumetric metering pump.
- The PN Series decompressors are air-cooled. Cooling takes place with a natural air flow on the outer fins of the body, made of high strength cast iron.
- The check valve is integrated in the decompressor.
- The decompressors feature a 4-way manifold. On request, a 5-way *Mixer*-type diverter valve is provided, designed for mixing the liquid in the tank of the tanker while it is being distributed on the ground.
- Transmission:
  - Direct with smooth or splined shaft.
  - Gearbox transmission (ASAE 1" 3/8) 540 or 1000 rpm.
  - With belts: the pulley must be fitted on the conical shaft of the pump.
  - Electric, hydraulic motor or with auxiliary motor.

### STANDARD EQUIPMENT

- Rotary vacuum pump with sliding vanes made of cotton cloth and phenolic resin (Bakelite).
- Counter clockwise rotation.
- Forced lubrication with **gear pump** and **oilers**.
- Built-in **oil tank**.
- **Check-valve** integrated in the decompressor.
- Pivoting suction and exhaust **conveyors** in aluminum alloy.
- **Direct transmission** with smooth or splined shaft (ASAE 1 3/8").
- **Gearbox transmission** with splined shaft.

### AVAILABLE ON REQUEST

- Special heat resistant vanes.
- **Clockwise rotation**.
- **Mixer type diverter valve**, 5-way.
- **Side oil tank** (only for PN 106).
- Transmission with **hydraulic motor**.
- **Pulley** for the belt drive.
- Drive by means of mechanical drive from **Power Take Off**.
- **Pneumatic actuator** for the vacuum/pressure changeover valve.
- **Hydraulic actuator** for the vacuum/pressure changeover valve.

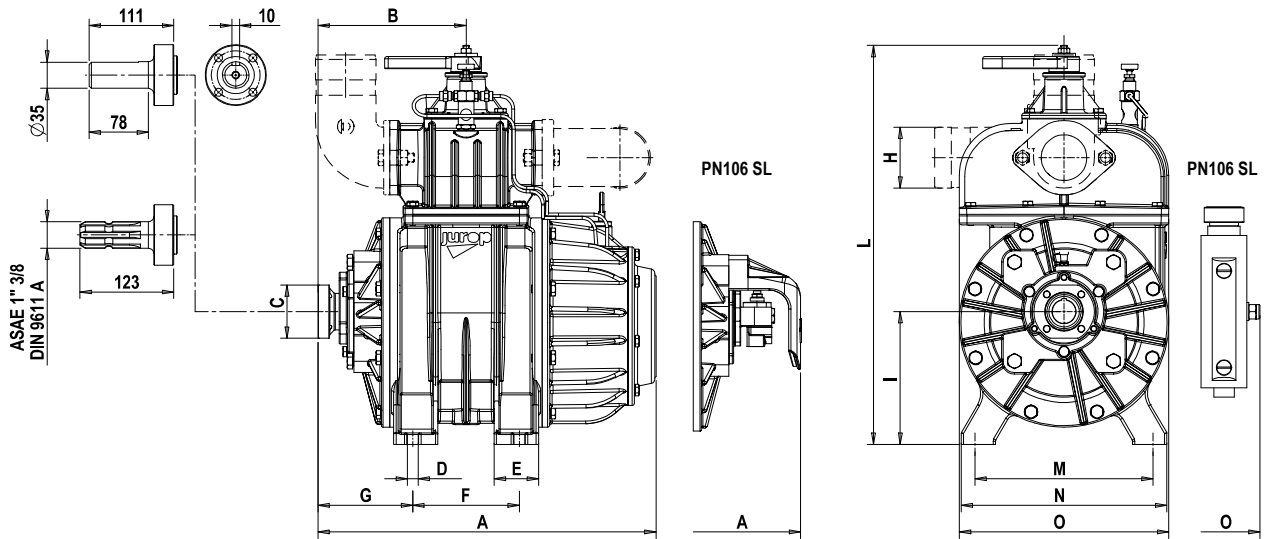
**2.1. Dimensions and arrangements**
**PN Direct transmission**

	A	B	C	D	E	F	G	H	I	L	M	N	O
PN 23	466	276	98	16	60	92	226	60	135	408	170	195	215
PN 33	546	306	98	16	60	160	226	60	135	415	170	195	215
PN 45	444	194.5	70	14	58	140	124.5	60/76/80	174	520	234	270	275
PN 58	504	225	70	14	79.5	190	130	60/76/80	167	542.5	234	270	275
PN 84	604	275	70	16	70	190	180	60/76/80	157	504.5	240	270	275
PN 106	694	319.5	70	16	70	290	174.5	60/76/80	169	517	240	285	339
PN 106 SL	685.5	319.5	70	16	70	290	174.5	60/76/80	169	517	240	285	339

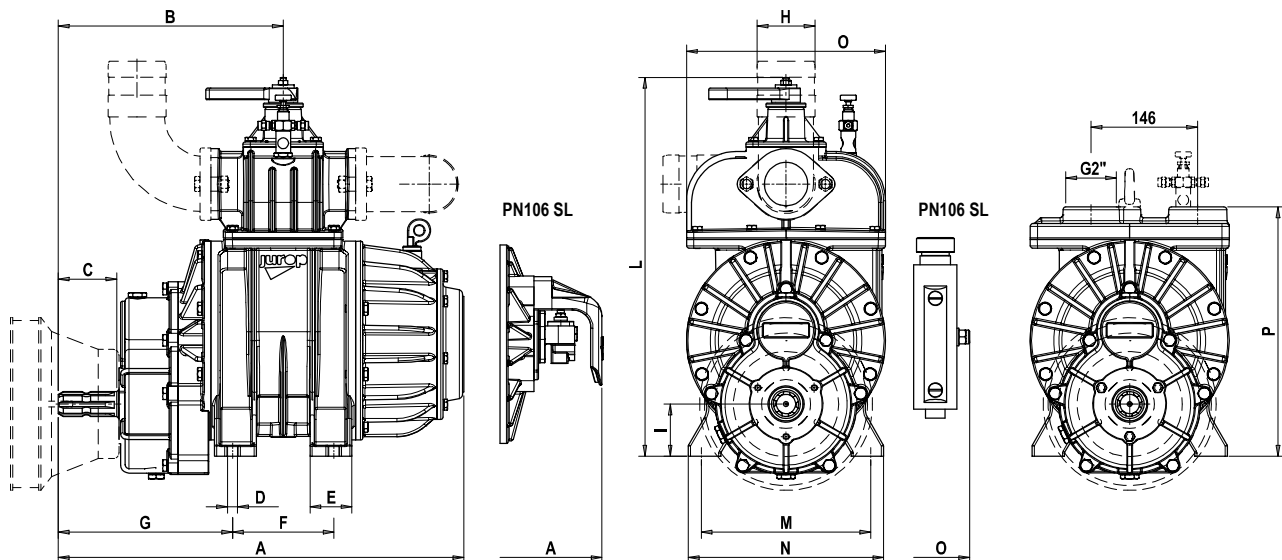
**PN Gearbox transmission**

	A	B	C	D	E	F	G	H	I	L	M	N	O	P
PN 23	475	280	87	16	60	92	235	60	58	408	170	195	215	-
PN 33	555	320	87	16	60	160	235	60	58	415	170	195	215	-
PN 45	560.5	311	86.5	14	58	140	241	60/76/80	72	520	234	270	275	345
PN 58	620.5	341	86.5	14	79.5	190	246	60/76/80	65	542.5	234	270	275	352.5
PN 84	720	391	86.5	16	70	190	296	60/76/80	55	520	240	270	275	329.5
PN 106	810.5	436	86.5	16	70	290	291	60/76/80	67	517	240	285	339	342
PN 106 SL	802	436	86.5	16	70	290	291	60/76/80	67	517	240	285	370	342

**PN Hydraulic motor**

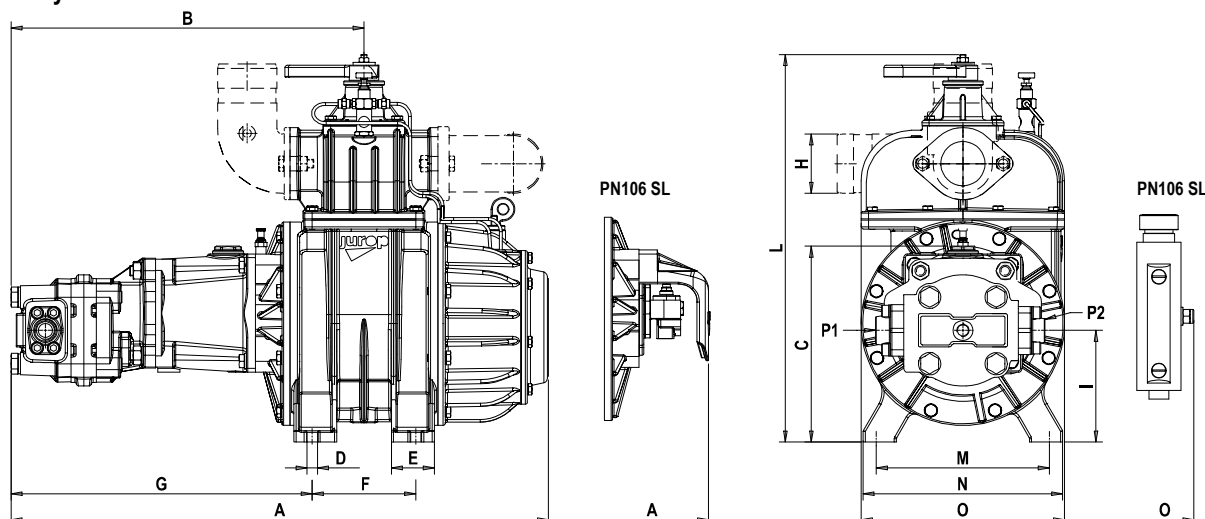

	A	B	C	D	E	F	G	H	I	L	M	N	O	P1	P2
<b>PN 23</b>	548	345	211	14	58.5	90	300	60	148.5	405	160	195	210	½	¾
<b>PN 33</b>	620	381	211	14	64.5	160	301	60	157	420	160	195	210	½	¾
<b>PN 45</b>	727	477.5	265	14	58	140	407.5	60/76/80	151	520	234	270	275	-	-
<b>PN 58</b>	793	513.5	257	14	79.5	190	418.5	60/76/80	143	542.5	234	270	275	1" ¼	1"
<b>PN 84</b>	904	574.5	247	16	70	190	479.5	60/76/80	133	504.5	240	270	275	1" ½	1" ¼
<b>PN 106</b>	976	587	260	16	70	290	457	60/76/80	138	517	240	285	339	-	-
<b>PN 106 SL</b>	970	587	260	16	70	290	457	60/76/80	138	517	240	285	370	-	-

**2.2. Performances**

Performances			PN 23	PN 33	PN 45	PN 58	PN 84	PN 106
Maximum speed	PN...D	rpm	1300	1300	1300	1300	1300	1300
	PN...M	rpm	540	540	540-1000	540-1000	540-1000	540-1000
Air flow at free air condition		l/min	<b>2600</b>	<b>3600</b>	<b>5300</b>	<b>6500</b>	<b>9000</b>	<b>11000</b>
		m³/h	156	216	318	390	540	660
Air flow at 60% vacuum rate		l/min	<b>2100</b>	<b>2900</b>	<b>4500</b>	<b>5800</b>	<b>8100</b>	<b>10000</b>
		m³/h	126	174	270	348	486	600
Maximum vacuum		%	90	90	92	92	92	92
Power required at 0,5 bar rel (1,5 bar abs)		kW	3,3	4,5	5,8	6,6	11,2	13,6
Max relative pressure (abs)	PN...D / M	bar	0,5 (1,5)	0,5 (1,5)	0,5 (1,5)	0,5 (1,5)	0,5 (1,5)	0,5 (1,5)
Max rel. pressure (abs) at not continuous duty	PN...FL	bar	-	-	3 (4)	3 (4)	3 (4)	3 (4)
Max rel. pressure (abs) at continuous duty	PN...FL	bar	-	-	1,5 (2,5)	1,5 (2,5)	1,5 (2,5)	1,5 (2,5)
Oil consumption		g/h	65/40	80/45	90/50	90/50	115/65	135/80
Oil tank capacity		l	1,2	1,2	2,3	2,3	2,3	2,3
Weight	PN...D	Kg	53	63	90	102	115	143
	PN...M	Kg	55	65	90	102	115	143
	PN...FL	Kg	-	-	84	95	108	136

REFERENCE CONDITIONS

Conveyed gas: air

Ambient reference temperature: 20°C (68°F)

Absolute reference pressure: 1013mbar (14.7psi)

Vacuum condition: atmospheric discharge

Pressure condition: atmospheric suction

Actual performance may vary of ± 5%

### 2.3. Usage limitations

Model	Max Speed – Operating Condition			P <sub>2</sub> (bar ABS)	T <sub>2</sub> (°C)	T <sub>2</sub> - T <sub>1</sub> (°C)
	Direct - HYD	Molt - 540	Molt - 1000			
PN 23	1300 - 1100	540 – 460 rpm	-	1,5	150	130
PN 33	1300 - 1100	540 – 460 rpm	-	1,5	150	130
PN 45	1300 - 1100	540 – 460 rpm	1000 – 850 rpm	1,5	150	130
PN 58	1300 - 1100	540 – 460 rpm	1000 – 850 rpm	1,5	150	130
PN 84	1300 - 1100	540 – 460 rpm	1000 – 850 rpm	1,5	150	130
PN 106	1300 - 1100	540 – 460 rpm	1000 – 850 rpm	1,5	150	130

P<sub>1</sub> : absolute pressure during suction  
 P<sub>2</sub> : absolute pressure during delivery

T<sub>1</sub> : temperature during suction  
 T<sub>2</sub> : temperature during delivery

### 2.4. Sound pressure level

		L <sub>w</sub> (A)					
Noise power of the only pump, without drive transmission suction group, mufflers.		[dB(A)]					
RPM	VACUUM/PRESSURE	PN 23	PN 33	PN 45	PN 58	PN 84	PN 106
NOMINAL SPEED	vac 80%	88	88	89	90	90	91
	Δ press 0,6 bar	100	100	102	103	103	104

### 2.5. Lubrication

Recommended oils and greases: *OIL TANK*

T °C	Viscosity	Type	ENI	ESSO	SHELL	TOTAL	MOBIL	BP	TEXACO HAVOLINE	Q8
From -15°C to +5°C	ISO VG 46	Mineral Oil	Acer 46	Nuto 46	Morlina S2 B 46	Drosera MS 46	Nuto H 46	Bartran HV 46	Rando HD 46	Schubert 46
From 0°C to +40°C	ISO VG 150	Mineral Oil	Acer 150	Nuto 150	Morlina S2 B 150	Drosera MS 150	Nuto H 150	Bartran HV 150	Rando HD 150	Schubert 150

Recommended oils and greases: *GEARBOX*

Viscosity	Type	ENI	ESSO	SHELL	TOTAL	MOBIL	BP	TEXACO HAVOLINE	Q8
ISO VG 220	Mineral Oil	Blasia 220	Spartan EP 220	Omala S2 GX 220	Carter EP 220	Mobilgear 630	Energol GR XP 220	Meropa 220	Goya 220



### 3. Safety and accident prevention

 **Attention: carefully apply these prescriptions.**

#### 3.1 General recommendations

- When transporting the compressor use proper slinging. Store the pump in stable places.
- Installation and maintenance must be carried out with the unit totally disengaged from its drive system and must be performed by qualified personnel.
- Use adequate clothing (avoid ties, loose sleeves, necklaces and so on) and suitable protection equipment (gloves, protection glasses, boots...).
- Before each maintenance operation, stop the pump and restore the atmospheric pressure.
- Make sure that all the parts of the unit are idle and cool, before performing any maintenance operation.
- To prevent errors and hazardous situations, establish what each operator is responsible for in the different maintenance operations.
- Do not start the machine if the protection devices provided for transmissions are removed. Replace damaged part.
- Final manufacturer must make the transmission inaccessible by means of a fixed guard or interlocked movable guard.
- Operators working nearby must avoid prolonged exposure to the noise emitted by the aspirator, if not equipped with the proper ear-protection devices (IPDs recommended: ear protectors).
- When the pump is running, some parts may reach very high temperatures (above 70°C). Use all necessary precautions to avoid contact.
- Avoid accidental suction of solids: solids may be projected at high speed through the exhaust manifold and cause injuries. A filter must be mounted on the suction line (Mesh 55).
- Pressure relief valve: point the air flux away from the operators.
- Do not use the aspirator over its designed limits: the machine may be damaged and the operator may be injured.

 **Do not exceed the speed and the power supply parameters indicated in the technical tables (see par. 2.2 - 2.3).**

- Based on the final use of the pump, the insertion in the housing machine and the typology of the same, the designer of the housing machine must apply safety signals (pictograms) to warn the operator on the risk still present. These pictograms essentially refer to three categories:
  - Signals prescribing the use of Individual Protection Devices (IPDs) such as, in this case, the use of gloves and ear protectors.
  - Signals indicating to pay particular attention to the dangers related to the machine's components, such as: risk of dragging in the transmission equipment and contact with hot surfaces.
  - Signals indicating specific parts of the machine for an easier identification, such as: greasing points, oil tanks, etc.

#### 3.2 Intended use

- Vacuum pumps of the PN series are commonly used on stationary or mobile equipment for suction and transfer by means of vacuum or so called pneumatic-transportation of liquid and solid wastes. Any other usage shall be considered improper.
- As cooling is given by atmospheric air, pumps are foreseen for non-continuous duty; suggested uninterrupted working-time: about 15 minutes. Overheating of the pump will cause serious damages of the same and/or blocking of the rotor. The model PN do not accept operating temperatures over 150 °C (300 °F), checked at not more than 150 mm from the discharge connections.
- Do not sack toxic substances and inflammable or explosive gasses, since the internal components of the pump may reach high temperatures.

 **Do not sack toxic substances and inflammable or explosive gasses, since the internal components of the pump may reach high temperatures.**

- Avoid suction of liquids or solids, they can seriously damage the pump.

 **Attention: liquids or solids infiltrations can seriously damage the pump.**

- Do not run the pump over its designed operating limits (see par. 2.3): it may break and transmission can be damaged.

#### 3.3 Conveyed fluids

- PN are suitable for conveying filtered air. Before conveying other kind of gases, verify compatibility with pump's characteristics.
- The machine was not designed and built to operate in environments with potentially explosive atmosphere (outdoor or indoor).
- Please contact JUROP's Technical dept. if necessary.

## 4. Installation

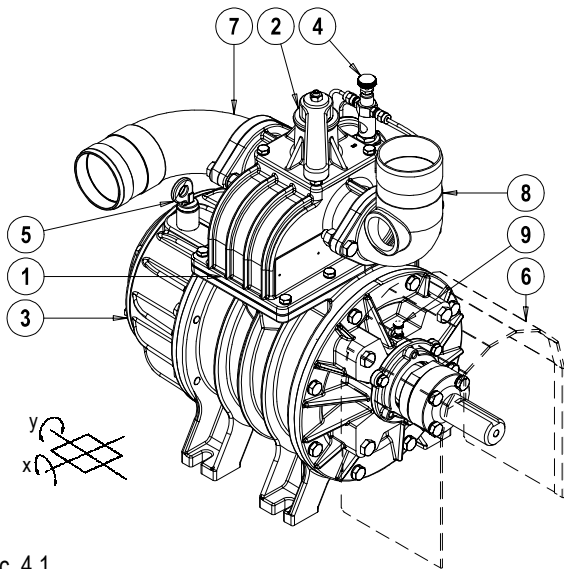

Pic. 4.1

Main components legend

1.	Manifold with built-in check valve
2.	Vacuum/Pressure change-over valve
3.	Rear oil tank with lubrication pump
4.	Drip oilers
5.	Oil filling port and dip stick
6.	Shaft protection
7.	Swivelling conveyor
8.	Conveyor with safety valve connection
9.	Front bearing lubrication

### 4.1. Compulsory accessories

- Compulsory accessories for a correct running of the pump:
  - Safety filter mounted between the pump and the secondary shutoff.
  - Over-pressure safety relief valve.

### 4.2. Checking upon receipt

- When the goods are delivered, make sure that all parts listed on the delivery note are in perfect condition and have suffered no damage during shipping.
- Remove the parts of the packaging that can be dangerous if sucked by the compressor.
- Make sure the vacuum pump has its identification plate. Pumps without such identification are to be considered anonymous and potentially dangerous: in such an event, they must not be used, otherwise the manufacturer will be deemed free from any liability whatsoever.

### 4.3. Storing in the warehouse

- If the pump will not be installed inside a short time after delivery:
  - Store in a closed and dry place.

- Remove the guards from the ports and spray a film of protective oil over the inner surfaces of the body, rotors and sides. Then attach again the guards.
- Renew the preserving oil periodically.
- To temporarily store a used pump, follow the instructions below:
  - Thoroughly clean the pump.
  - Equip the pump with suitable anti-corrosion protection.

### 4.4. Handling and installation

- Before each movement, verify that the lifting equipment has a suitable capacity (check the weight of the pump, possibly showed in this manual, in the paragraph 2.2).
- Do not lift the packaging or the machine when moving more than 50 cm from the ground. Proceed with the final lifting only near the installation point.
- Harness the machine with suitable straps / chains near the main body, paying attention to the position of the mass centre of gravity to ensure the load stability.



**Warning: do not stand under the machine when it is lifted during the installation.**

### 4.5. Mounting

- The pump must be assembled for an easy access for maintenance operations and secured rigidly to a frame or levelled base (max. 3° slant to the horizontal plane. See Fig. 4.1). The base must be such as to avoid vibrations, bending or deformation.
  - It is recommended to install the pump on vibration adsorbing pads to reduce the noise and vibrations produced during its operation.
  - Leave enough space around the pump to allow the free circulation of air for cooling; avoid exposure to dirt and debris.
  - Provide the necessary space to reach all points of lubrication control (oil level), and the oil tank filler cap, the lever of the 4-way switch, vanes inspection ports. See Pic. 4.1.
- The oil tank is mounted on the rear side of the pump. Instead for PN 106 the oil tank is mounted on the suction side of the housing.
- Provide for suitable manoeuvring spaces of the inverter lever. The control lever has two possible switching positions well defined by the latches and numbers reported on the fusion. It is directly connected to the internal diverter tang of the inverter, making it very intuitive: 90° of the lever switching corresponds to 90° of the inverter switching.
- Based on the functionality of the system which will house the decompressor, the designer of the end machine, must:
  - Properly signal the functionality of the inverter according to the position of the manual operating lever or of the pneumatic actuator or of the hydraulic one.
  - Install suitable pressure and / or vacuum restrainer valves near the inlet and outlet points of the machine.
- In the event that the pump is electrically isolated, connect it to the ground or make it equipotential with the housing machine. Check that the paint does not prevent its passage.

• The machine expels gas during delivery at temperatures that can reach the maximum permitted values for operation, with its lubricating oil in suspension. Oil consumption is stated in paragraph 2.2, the quantity of consumed oil corresponds to the quantity of oil emitted at delivery.

• In case of PN with hydraulic motor, provide the necessary space to disassemble the motor itself and proceed with joint lubrication.

#### 4.6. Vacuum / Pressure line

• See the following picture.

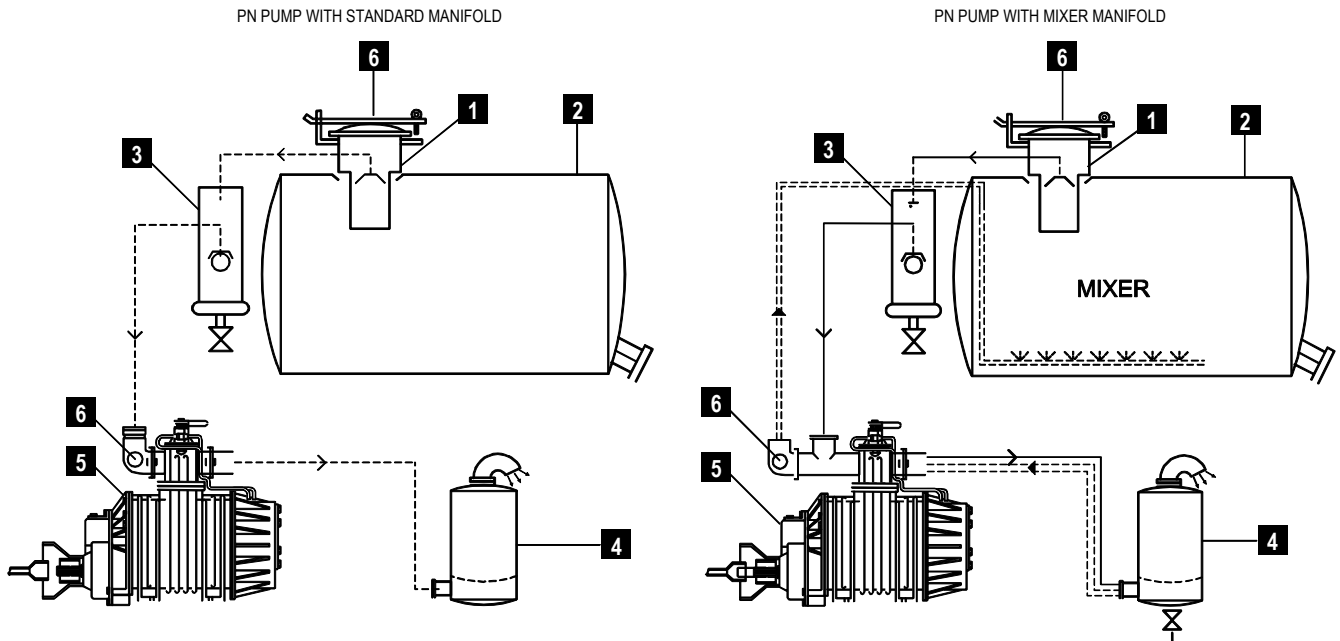

Pic. 4.2

#### Vacuum / Pressure line components

1	Primary shutoff
2	Tank
3	Secondary shutoff
4	Silencer + oil trap
5	PN pump
6	Safety relief valve

• The hoses connecting the suction and exhaust ports of the vacuum pump must be of adequate diameter (suggested not less than 3") and of oil and corrosion resistant materials and before connecting them, make sure that they are perfectly clean in the inside.

• The weight or dimensions of the pipes must in no way stress the pump body. Use high temperature resistant rubber sleeves.

• Remove the port guards when mounting. The pipes and components of the whole line must be clean.

• Avoid constrictions and tight curves where they are not essential.

• Connect the pump to the tank through the suction manifold which has a threaded port for fitting the over-pressure valve.

• The exhaust pipes can reach high temperatures. Protect those adequately from the operator reach.

• A non-return valve on suction pipe avoids rotation in the opposite direction when the pump stops.

• To avoid that foreign liquids will enter the vacuum pump it is necessary to mount on the suction line an over-flow valve of "floating-

ball" type (Fig. 4.2. - pos. 1). The flow section of this valve must be equivalent to the suction hose's one.

• It is also necessary to have on the line a suitable air filter for preventing solids to be sucked inside the vacuum pump. It is also recommended to mount a "secondary shutoff" of floating-ball type (Fig. 4.2 - pos. 3) between vacuum pump and over-flow (primary shutoff).

• Called also 4-way valve, normally is manually operated but it can be at any time transformed in pneumatically or hydraulic operated upon request of the appropriate kit.

• During normal running of the pump the resulting noise should be reduced by means of a suitable silencer (Fig. 4.2 - pos. 4) mounted as close as possible to the pump itself. It has to be dimensioned for the air flow produced by the pump model. The oil used for the pump's inside lubrication has to be separated from the exhausted air by means of an adequate oil-separator, placed directly inside the silencer. The silencer is fitted also with a draining tap for the collected oil and condensed liquids.

**Do not dispose of in the environment. Dispose of in compliance with the standards in force.**

• Over-pressure safety relief valves (Pic. 4.2 - pos. 6). It must be dimensioned to discharge the entire air-flow of the pump. The adjustment of this valve has to be kept inside 10% of tolerance of the pump's working pressure and in any case, it has to stay inside the given value of the tank's work pressure.

- Vacuum control valve has to be fitted on the suction piping, if the tank's characteristics or the vacuum line will need this kind of vacuum-limiting device.

- In the event of pressurised operation, the rotation of the 4-way diverter valve enables suction from the silencer and air to be sent into the system. Check the rotation capacity so as not to generate excessive pressure in delivery.

- In the event of overheating, the opening of the safety gate valve applied on the suction inlet does not cool the pump working under pressure. Stop transmission.

- The valve at the decompressor suction inlet avoids rotation when it is stopped under load, but the circuit must be bled:

- Before servicing the decompressor or transmission. The pressure difference inside the system can make the machine run;
- Before restarting the machine: it requires high starting torque.



**Attention: if the decompressor is stopped under load, bleed the circuit before any maintenance operations.**

- An adjustable curved pipe is installed on the outlet of the silencer, in order to prevent rain from entering and to enable positioning (during installation) of the output airflow.

- Direct the silencer discharge outlet away from the silencer suction inlet in order to prevent the input of hot fluids into the injection inlet.



**Direct the silencer discharge outlet away from the silencer suction inlet in order to prevent the input of hot fluids into the injection inlet.**

- An oil-separator must be installed in correspondence of the discharge line of PN. Besides reducing the noise produced by the air flow along the vacuum line, the silencer also traps the oil vapor at the outlet due to decompressor lubrication.

#### 4.7 Vacuum-pressure inverter: remote control actuators

- A specific design of the vacuum-pressure diverter available on request enables the application of a pneumatic or hydraulic angular actuator (90°).

- See the exploded view at the end of the manual for spare parts.

	Pneumatic actuator	Hydraulic actuator
Fluid	Filtered, dried compressed air	Hydraulic oil ISO-L-HM
Filtration	ISO 8573-1 classe 4 (15 micron)	ISO 4406 21/19/16
Temperature	-20 ÷ +80 °C	-20 ÷ +80 °C
Rated pressure	5.6 bar	150 bar
Maximum pressure	8.4 bar	200 bar
Supply holes	G 1/4	G 1/8

#### Hydraulic actuator installation

- Adjust movement speed using the two built-in valves.
- Use a closed-center distributor or apply a block valve.

#### Pneumatic actuator installation

- Adjust movement speed by applying two unidirectional flow control valves.

#### For both actuators

- Adjust speed: full rotation should not take less than 1 second.
- Fluid filtration: ensure a level equal to or greater than the recommended value.
- In the event of a (hydraulic or pneumatic) supply failure, the suction unit inverter will remain in the same position it was when the failure occurred.

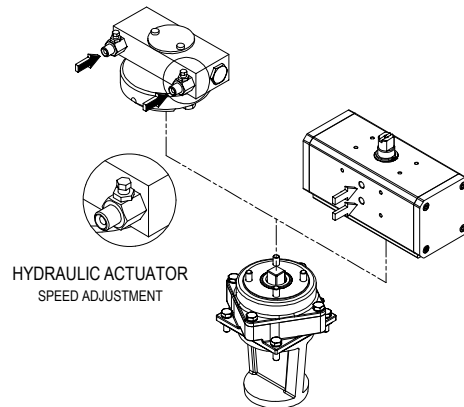

Pic. 4.3

#### Maintenance

- The diverter is adjusted before shipment and does not usually require further adjustments.

- Diverter lubrication:

- Use Lithium grease NLGI 2. Quantity: 80-100 g every 1000 working cycles.
- Do not grease using excessive amounts of grease.

- Hydraulic actuator: the control valves are equipped with an internal metal filter. Disassemble and clean if movement stops.

- Pneumatic actuator: for non-dried air, use temperature 0 ÷ +80°C.

- The following figure shows a possible schematic view of a correct hydraulic connection.

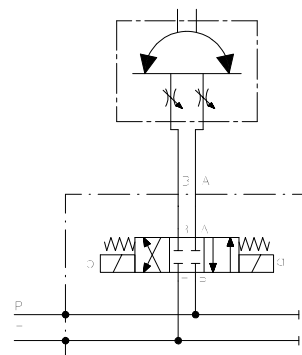

- The following figure shows a possible schematic view of a pneumatic connection.

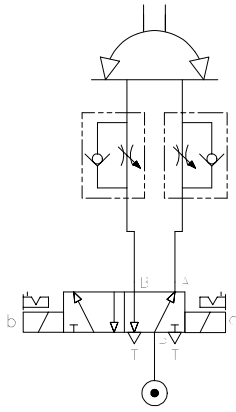

• In case of interruption of the pneumatic or hydraulic supply, the inverter of the suction unit remains in the same position it was when the failure occurred.

### 4.8 Pump mounting - drive connection

- For the machines of this series, the allowed power transmissions are:
  - Direct transmission (e.g.: from agricultural cardan shaft)
  - Oil hydraulic transmission (HYD).
- Protect with a fixed or interlocked guard and signal with pictograms the power transmission chosen and applied by the final installer, if there is the possibility that the operator will come into contact during handling.

#### A) Cardan shaft drive

- Use telescopic cardan shafts.

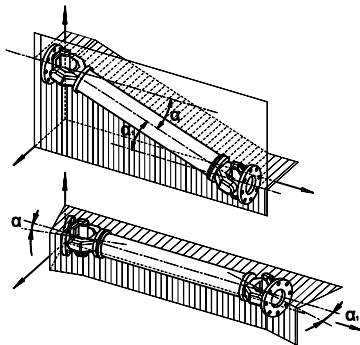

Pic. 4.4

- In order to achieve a uniform motion of the driven shaft, the following requirements must be met (see Pic. 4.4):
- Equal working angle  $\alpha$  and  $\alpha_1$  of both couplings;
  - The internal fork joints must be coplanar;
  - Both driven and driving shafts must be coplanar.

- It is also recommended working with limited articulated joint angles (max 15°) and disengaging the transmission for those operations requiring great angles (steering or lifting).

**Follow the rotation direction as indicated on the pump front conveyor protection. Follow the instructions of the cardan shaft's manufacture.**

- Use the cardan guard supplied with the pump, by fixing it to the pump itself.

**Use the cardan guard supplied with the pump, by fixing it to the pump itself. In any case, the installation, by the final installer, must comply with the current EC accident prevention regulations and must be compatible with the geometry of the protection cap supplied with the machine.**

- The protection must not be removed; in case of removal, it is the responsibility of the final installer to provide for suitable guards according to the assembly.
- It is the responsibility of the final installer to provide for suitable guards, in presence of transmission shafts exposed during normal operation.

#### B) Belt drive

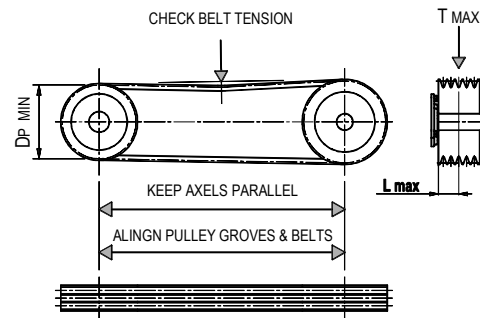

Pic. 4.5

- Do not apply pulleys on the cylindrical shaft of the decompressor. Use pulleys supplied by JUROP which are fitted directly on the conical shaft of the rotor.
- Do not apply excessive belt tension: use pulleys with a primitive diameter equal to or greater than that recommended. Do not exceed the permitted belt tension.
- If a pulley diameter other than those available is required, contact JUROP Customer Service.
- Provide belt guards in compliance with current accident prevention regulations that do not prevent ventilation and cooling.

Model	Max. Speed (rpm)	T. max (N)	Min. pitch diameter (mm)	Nr. Grooves	Belts type
PN 23-33	1300	1200	118	3	SPB
PN 45-58	1300	1400	150	4	SPB
PN 84-106	1300	2400	150	4	SPB

Pitch Diameter. min.: Minimum drive of pulley pitch diameter.



**C) Hydraulic drive transmission**

Model	Displacement	Operating pressure (max. vac.)	Operating pressure (1 rel. bar)	Flow at Max Speed	Max pressure draining line	Max. pressure motor exhaust	Max pressure
PN 23	19 cc/rev	100 bar	130 bar	26 l/min (1300rpm)	-	5 bar	250 bar
PN 33	19 cc/rev	160 bar	200 bar	26 l/min (1300rpm)	-	5 bar	250 bar
PN 45	34.5 cc/rev	110 bar	140 bar	46 l/min (1300rpm)	5 bar	5 bar	230 bar
PN 58	44 cc/rev	110 bar	140 bar	59 l/min (1350rpm)	5 bar	5 bar	220 bar
PN 84	61 cc/rev	120 bar	150 bar	84 l/min (1300rpm)	5 bar	5 bar	170 bar
PN 106	72 cc/rev	120 bar	160 bar	98 l/min (1200rpm)	5 bar	5 bar	230 bar

(\*) : Oil temperature, used in the main circuit.

• **Fluid:** mineral oil for hydraulic systems in compliance with ISO/DIN.

Temperature	Optimum viscosity ale	Max. viscosity allowed
-20 / +80 °C	12 – 100 cSt	750 cSt

• **Filtration:** class 21/19/16 contamination according to ISO 4406 to be obtained with a βx = 75 filter.

• **Check circuit connections:** they must be applied in the same rotation direction as that indicated by the arrow on the pump front flange.

• **Draining:** connect directly to the tank above the maximum oil level. Operating without draining line may damage the motor.

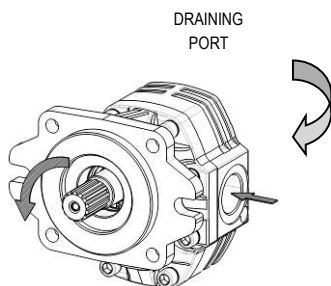

Pic. 4.6

• **Distributor:** open-centre distributor in central idle position (vacuum pump off). It must be equipped with an adjustable overpressure safety valve.

• **Motor pipeline:** outlet pipe must not be of a smaller diameter than that of the inlet port. Inlet pipes always have a diameter smaller than outlet pipes. Choose preferably flexible pipes to avoid vibration transmission.

• **Tank:** with suction pipe and return separated by baffles. If necessary, use a heat exchanger to avoid oil heating above 70-80°C and protect it from extreme pressure with a pressure relief valve. Minimum approximate capacity: as twice as the circulation flow.

• **Starting-up:** be sure that the system is well cleaned and pour oil into the tank and into the motor housing (necessary to lubricate the internal bearings).

• Vent the circuit and adjust the overpressure safety valve to the lowest possible value.

• Check the oil tank level.

• Increase pressure and rotation speed until operating values are reached.

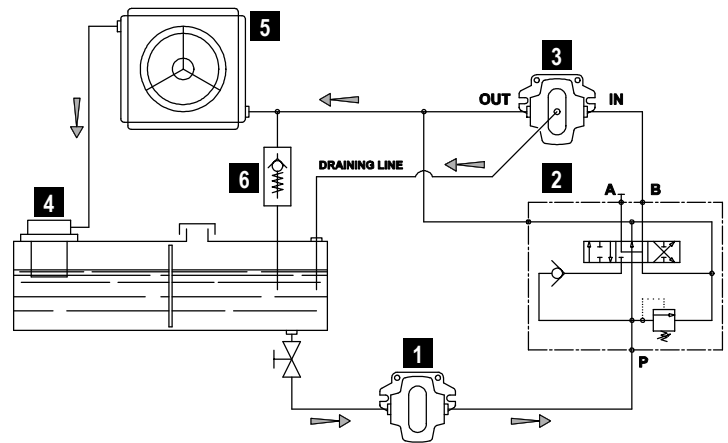

Pic. 4.7

1	HYD Pump	4	Oil Filter
2	Distributor	5 *	Heat exchanger
3	HYD Motor	6 *	Safety valve

\* optional components

• The machine/system manufacturer is responsible for dimensioning the lines.

**The machine/system manufacturer is responsible for dimensioning the lines.**

## 5. Start up

### 5.1. Pump starting-up

- Before starting the equipment check the lubricating oil level of the pump by means of the proper dip stick.
- Refill the tank with lubrication oil.
- Check the oil level in the gear box (if the pump is provided with it).
- In order to choose the most suitable oil, see paragraph. 2.5.
- Check that all protection and safety devices are correctly installed.
- Check that no obstacles obstruct the vacuum and pressure line or the air injection cooling system.
- Check rotation direction: open all system valves and start running at slow speed.

**Do not rotate in the wrong direction: pump may be damaged.**

- Check which position of the 4-way integrated valve lever allows vacuum or pressure functioning.
- Rotating the handle of the 4-way valve (pos. 1÷2 - See following figure) the pump changes over from vacuum to pressure (or vice versa).

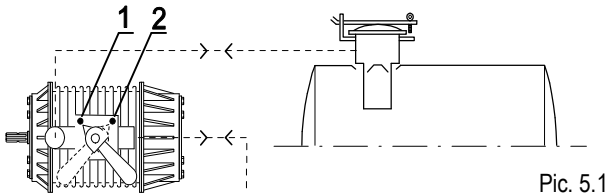

- In case the pump is connected to the tank with the rear connection (oil tank side) the functions "Vacuum - Pressure" will be reversed.

Manifold	Drive	Handle pos.	Pump function
STANDARD	Direct drive left	1	Pressure
	Gearbox right	2	Vacuum
	Direct drive right	1	Vacuum
	Gearbox left	2	Pressure
MIXER	Direct drive left	1	Vacuum
	Gearbox right	2	Pressure
	Direct drive right	1	Pressure
	Gearbox left	2	Vacuum

- Be aware not to place the handle in neutral position (half way between the two end positions) otherwise the pump will be by-passed (actually runs idle).

**Be aware not to place the handle in neutral position otherwise the pump will be by-passed.**

- Close the valve and increase vacuum rate (or operating pressure).
- Check loading and operating speed for vibrations or unusual noises.

**This vacuum pump is designed to work at maximum speed. For longer operating we recommend the pump be run at working speed.**

- Prepare adequately transmission.

### 5.2. Operating precautions

- Run the vacuum pump at a room temperature of -20°C e +40°C.
- Do not make the vacuum pump overheat. Maximum air temperature on exhaust (or delivery) side: 150°C.
- Do not operate the pump without lubrication: it may cause quick wear and possible breakdown of vanes.
- Do not start running the pump under load: that causes stress to the drive system and the hydraulic motor.
- Check rotation speed. The vacuum pump must never exceed the maximum speed or run below the minimum speed.
- Do not accidentally operate the pump in the wrong direction: it may break the vanes.
- Do not convey the exceeding delivery outlet towards the suction port, otherwise it will sack warm gas.
- Control the air flow by adjusting the rotation speed: do not use the pressure relief valve to discharge the exceeding flow.
- Once that the wanted vacuum rated has been attained it is recommendable to decrease the speed, (see par. 2.3). This useful procedure, that will not increase the time requested to fill up the tank, will however result in a lesser wear of the vanes. It is suggested to reduce the speed also when operating with pressure.
- When, exhaust temperature is reduced, vane durability is increased and both oil consumption and power absorption are reduced.

**Once the needed vacuum rate has been reached, we recommend reducing the vacuum pump speed to its working speed.**

- After operation in dusty environments, after accidental sucking of liquids inside the pump or before a long inoperativity period it is recommended to wash the pump inside according to the following procedure:

1. Before washing the pump, be sure that it has cooled down. To obtain this in a short time, it is possible to run the pump for a few minutes at zero vacuum conditions, or stop it at all;

**Attention: Do not carry out this operation on very hot pumps (for example after a working day) until they have cooled down.**

- Use 1-2 liters of water mixed with a non-flammable detergent. We suggest some product like Henkel Bonderite C-NE 5225: 5% concentration in water. This detergent grants a good protection against rust and oxidation.
- Use one of the openings placed in the vacuum line (closet on the pump) to suck some water mixed with detergent.
- Start the pump at low speed leaving opened all the suction valves in the tank, in order to keep low the vacuum rate (max vac. 10-20%). Let the detergent mix entering the pump very slowly.
- The detergent mix stays suspended in the pump inside, before being expelled through the exhaust silencer.
- After keeping the pump speed for a while to make the product reaching the internal parts, it is necessary to dry the pump

preventing oxidation. When the detergent mix is finished, continue running the pump at the lowest possible vacuum rate for a few minutes, then close venting and suction valves up to 50-60% maximum, for a couple of minutes. With this operation the pump will dry from the heated air and protected from the chemical attack of the detergent.

- Washing the pump with this detergent guarantees a protection after some days of inoperativity. If the pump is not used for more than two weeks, after having washed and dried the inner parts as described above, it is recommended to suck slowly 200 cc anti-rust and water-repellent protective oil (or, if not available, a very fluid gear oil).

 **Attention: do not carry out also this operation on very hot pumps (for example after a working day) until they have cooled down.**

 **In case the exhaust line cannot be disconnected, drain the liquids accumulated in the separator of the exhaust silencer.**

- Do not convey the exceeding flow outlet towards the suction port.
- Control the air flow by adjusting the rotation speed: do not use the safety relief valve to discharge the exceeding flow.
- Do not squeeze the hoses/pipes.
- If the decompressor operates in vacuum or under pressure with a capacity environment (such as a cistern) and is configured in the "FL" flanged version (without manifold with 4-way valve and non-return valve), it is advisable to intercept the working line of the machine when it is stopped, to prevent contrary rotations until the rebalancing of the pressures. The interception can take place through a controlled valve or an automatic unidirectional valve (swing valve).
- Avoid starting the pump under load: motor and drive system can be excessively stressed.

## 6. Maintenance

### 6.1. Ordinary maintenance

- Any interventions must be performed when the machine is cold, stopped and switched off.
- Installation and maintenance must be operated only by qualified personnel wearing the proper clothes and the necessary tools as well as protection devices.
- Use suitable protection equipment (gloves, protection glasses, boots...)
- In the following table summarizes the main controls to be performed and the frequency of intervention.

Operating Condition	Maintenance Area	Check	8H	50H	500H	1000H
OPERATING	Vacuum line	Check safety valve (non-return valve)				
		Operating pressure				
	Transmission / Pump	Lubrication: dripping into oilers				
		Rotation speed				
Sound pressure level (also HDR motor)						
STANDSTILL	Vacuum line	Suctions filters				
		4-way changeover valve: check and lubricate				
	Pump	Clean oilers glasses				
		Check oil level				
		Check vanes wear				
		Change oil (*)				
	Overall	Pump's inner washing (**)				
		Greasing				
		Check cardan shaft drive				
		Check transmission pulley				
		Swing valve wear check				

(\*) The first oil change must be done inside 500 hours operation. Following changes every 5000 hours or 12 months. In order to choose the most suitable oil, see paragraph 2.5.

(\*\*) After operation in dusty environments, after accidental sucking of liquids inside the pump or before a long inoperativity period it is recommended to wash the pump inside according to the procedure described at paragraph 5.2.



### Checking the oil tank level

- Before starting the machine, check the lubricating oil level.

REAR MOUNTED TANK

SIDE MOUNTED TANK

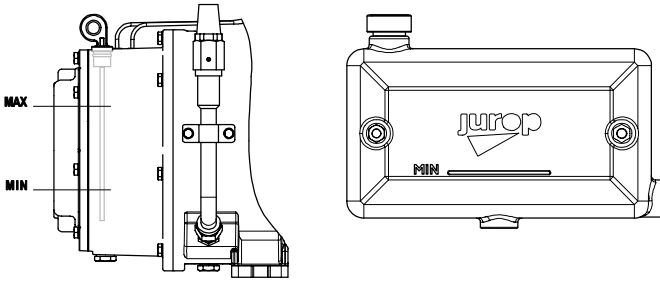

Pic. 6.1

- Do not run the pump with oil level under the minimum level: that may lead to dry functioning and cause serious damages. (Pic. 6.1).
- Rear mounted tank capacity: **1,2 l (PN 23-33)** and **3,2 l (PN45-58-84-106)**.
- Side mounted tank capacity: **4 l**.
- Also check that the oil level in the gearbox reaches the side level hole. Top up through the hole in the upper part.
- Top up with fresh and clean oil only; use the oil required in paragraph 2.5 or equivalent.

### Checking lubrication

- Keep clean the oilers glasses and check dripping into the same oilers.
- Check dripping in the oilers on a frequent basis during operation.
- Be sure it is regular (about 45-50 drops/min at 1300 rpm) to grant a correct lubrication of the pump. At lower speeds, the number of drops must be directly proportional.

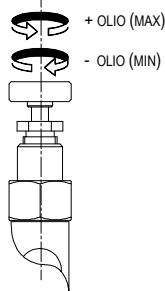

Pic. 6.2

**If there is no lubrication, the machine overheats and the internal components deteriorate quickly. Stop the machine, check the oil level and the lubrication pump.**

### Checking the vanes wear (PN23...58)

- Carry out the inspection by removing the manifold. Insert, near the outlet/inlet, a 6 mm diameter dipstick with the chamfered end facing towards the bottom. After resting the dipstick on the rotor, carry out a first measurement by making a mark on the dipstick.
- Turn the shaft manually and rest the rod on the outer diameter of the rotor, making a mark on it, turn the shaft again until the rod enters

the vane slot, mark it again and measure the difference between the two marks.

- Repeat the operation on all the vanes. If the difference exceeds 10 mm, the vanes must be replaced as soon as possible. Replace all the vanes at the same time.
- At the end of the operation, reassemble the manifold.

### Checking the vanes wear (PN84 - PN106)

- Unscrew the vanes wear check-plug on the front flange. See Pic. 6.3.

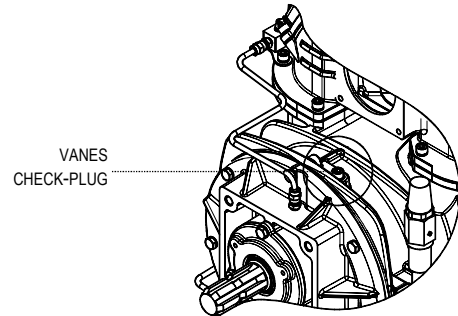

Pic. 6.3

- Turn the shaft by hand until vanes appearance.
- Vanes usually slip on seat bottom due to gravity. Check their right entry in the seat.
- Inserire, come in Fig. 6.4, un'astina  $\varnothing 6$  mm.
- Turn the rotor slowly until the stick touches the vane in idle position in its seat. The vanes slide to the bottom of the seat due to gravity: check they really do and mark again on the stick.
- Repeat the same procedure for all the vanes. If wear exceeds 10 mm: replace the vanes as soon as possible.

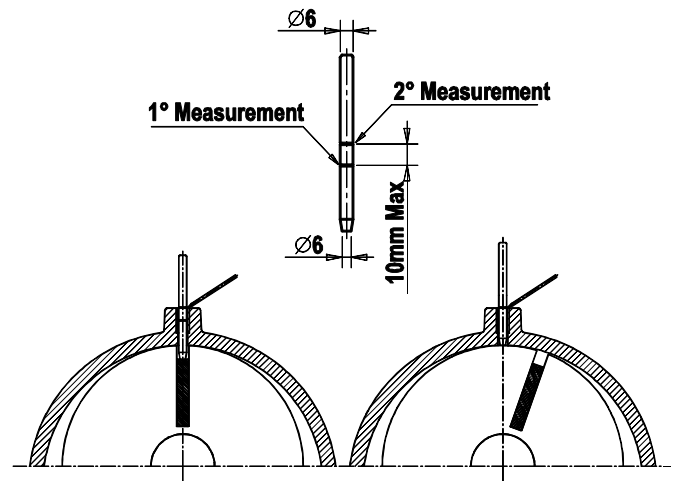

Pic. 6.4

- Replace all the pump vanes at the same time.

**Replace the vanes when their wear exceeds 10 mm (L – L min): they may break. Replace all vanes at the same time.**

- At the end of this checking do not forget to replace the plug on the port.

## 6.2. Extraordinary maintenance

• Except for the cases described below, extraordinary maintenance on a PN must be carried out by specialized personnel only; otherwise the guarantee will be invalidated.

• All extraordinary maintenance interventions must be carried out when the machine is cold, stopped and switched off. Implement the safety instructions reported in the “Safety and accident prevention” Chapter, before performing any maintenance operation.



**Follow the safety prescriptions as described in Cap. “Safety and accident prevention”.**

### Replacing the vanes

• Disassemble the decompressor from the base and wash it before starting to work.

• It is preferable to work on the front side of the machine. The drawing represents the different components to be removed to replace the vanes.

• Dismantle the transmission parts:

- Pulley.
- Hydraulic transmission parts.

Check their conditions and replace the worn components.

• We recommend replacing components subject to wear (specific kits are available, see the exploded view in the manual):

- Seal rings.
- O-Rings and other gaskets.

### PN 23-33 with Direct Transmission

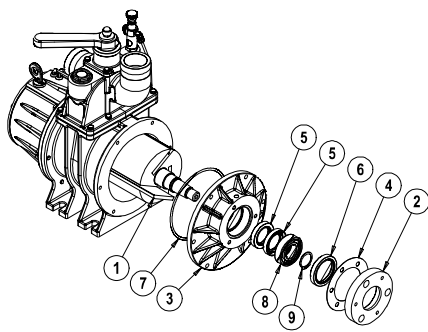

Pic.6.5

Pos	Code	Description
1	-	VANE
2	1610500900	FLANGE
3	1610504000	FRONT FLANGE
4	1680701000	FLANGE GASKET
5	4022200025	SEAL 55X35X10
6	4022200037	SEAL 65X48X10
7	4022200230	O-RING 4575
8	4023100018	BEARING 6206-NMQ
9	4026510025	SEEGER E 30

### Disassemble operation

- After removing the cardan shaft guard and the front shaft (smooth / broached), remove the direct intake flange (2) and its gasket (4).
- Remove the decompressor flange (3) and do not lose the underlying O-Ring (7).
- Support the shaft before removing the flange: the weight of the rotor must not cause any abnormal stress on the internal components.
- Remove the worn vanes (1).
- Complete the disassembly procedure:
  - Remove the seal ring (6) from the decompressor flange (3) and the snap ring (9);
  - Finally, remove the bearing (8) and the seal rings (5).

### Assemble operation

- Lubricate and then insert all the vanes into their seats (1). Insert with the chamfer in the correct position, see Pic. 6.6.

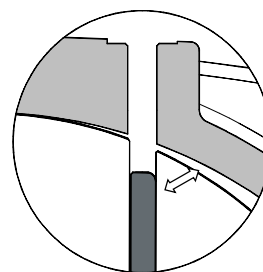

Pic. 6.6

• Reassemble the components in the following order:

- Secure the O-Ring (7) using some grease, in the seat on the flange (2). It is recommended to replace the O-Ring (7).
- Fit the new seal rings (5) on the flange (2): avoid damaging the seal rings (5) while fitting them on the shaft. Centre properly and tighten the screws. Insert the bearing (8) properly and all the way into its seat.
- Insert the snap ring (9) and the seal ring (6).
- Fit the direct intake transmission flange (2) with its gasket (4). It is recommended to replace the gasket.
- Smooth / broached shaft.
- Cardan shaft guard.

### PN 45-...-106 with Direct Transmission

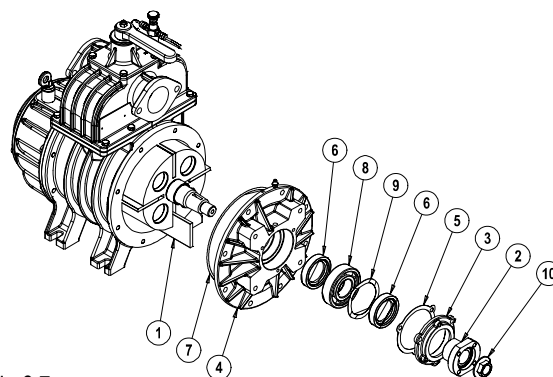

Fig.6.7

Pos	Code	Description
1	-	VANE
2	1610006600	FLANGE
3	1610500400	FRONT OIL SEAL FLANGE
4	1610500500	FLANGE
5	1680700400	FLANGE GASKET
6	4022200110	SEAL 72X48X15
7	4022200240	O-RING 4825
8	4023100040	BEARING 6308
9	4026300020	COMPENSATION RING
10	4026305614	SELF-BLOCKING NUT M24X2

### Disassemble operation

- After removing the cardan guard and the front shaft (smooth / broached), loosen and remove the self-locking flanged nut (10) and the direct intake transmission flange (2).
- Remove the front oil seal flange (3) and its gasket (5).
- Remove the decompressor flange (4) using the threaded holes for removal. Do not lose the underlying O-Ring (7).
- Support the shaft before removing the flange: the weight of the rotor must not cause any abnormal stress on the internal components.
- Remove the worn vanes (1).
- Complete the disassembly procedure:
  - Remove the bearing (8) and the seal rings (6) from the decompressor flange (4);
  - Do not lose the compensation ring (9).
  - Remove the seal ring (6) from the front flange (3).

### Assemble operation

- Fit the seal ring (6) on the transmission flange (4).
- Reassemble the components in the following order:
  - Replace the O-Ring (7) and secure using grease in the front flange seat.
  - Replace the seal ring (6).
  - Fit the flange (4) on the body: avoid damaging the seal rings (6) while fitting them on the shaft. Insert the bearing (8) properly and all the way into its seat and fit the compensation ring (9).
  - Replace the seal ring (6) on the flange (3) and mount on the flange (4) replacing the gasket (5).
  - Direct intake transmission flange (2) and self-locking flanged nut (10)
  - Smooth / broached shaft
  - Cardan shaft guard.

### PN with Gearbox

#### Disassemble operation

- Remove the transmission, if any. Check its conditions.
- Remove the cardan shaft guard (15).
- Remove the gearbox (3) and relative gasket (6).
- Remove the seal ring (7) and the bearing (11) fitted on the gear wheel (4). At the same time loosen and remove the flange nut (14).

- Remove the gear wheel (4) and pinion (5).
- Remove the decompressor flange (2) using the threaded holes for removal. Do not lose the underlying O-Ring (9).
- Support the shaft before removing the flange: the weight of the rotor must not cause any abnormal stress on the internal components.
- Remove the worn vanes (1).
- Complete the disassembly procedure:
  - Remove the bearings (10) and (12), the seal ring (8) from the decompressor flange (2);
  - Do not lose the compensation ring (13) fitted in models PN 45-58-84-106.

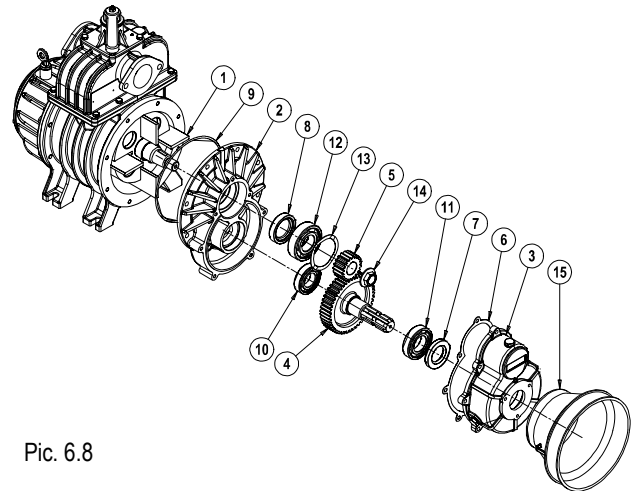

Pic. 6.8

Pos	Code	Description
1	-	VANE
2	1610503900	GEARBOX FLANGE PN23-33
	1610500000	GEARBOX FLANGE PN45-...-106
3	1612501300	GEARBOX PN23-33
	1612503100	GEARBOX PN45-...-106
4	1651000300	GEAR PN23-33
	1651000000	GEAR PN45-...-106
5	1651000200	PINION PN23-33
	1651000100	PINION PN45-...-106
6	1680700900	GASKET PN23-33
	1680700000	GASKET PN45-...-106
7	4022200032	SEAL PN23-33
	4022200040	SEAL PN45-...-106
8	4022200025	SEAL PN23-33
	4022200110	SEAL PN45-...-106
9	4022200230	O-RING PN23-33
	4022200240	O-RING PN45-...-106
10	4023100018	BEARING PN23-33
	4023100020	BEARING PN45-...-106
11	4023100020	BEARING PN23-33
	4023100130	BEARING PN45-...-106
12	4023100018	BEARING PN23-33
	4023100040	BEARING PN45-...-106
13	4026510025	SEEGER PN23-33
	4026300020	SEEGER PN45-...-106
14	4026305612	NUT M20X1,5
	4026305614	NUT M24X2
15	4029602806	DRIVE SHAFT PROTECTION

### Assemble operation

- Lubricate and then insert all the vanes into their seats (1).
- Reassemble the components in the following order:
  - Decompressor flange (2): avoid damaging the seal rings (8) while fitting them on the shaft. Centre properly and tighten the screws. Insert the bearings (10) and (12) properly and all the way into their seats. It is recommended to replace the O-Ring (1).
  - Gear wheel (4) with relative bearing (11) and seal ring (7).
  - Pinion (5) and self-locking flanged nut (14)
  - Gear box and its gasket.
  - Cardan shaft guard.



**Attention: do not damage the components during assembly by forcing them excessively.**

### General warnings

• When changing the vanes do not forget to carefully clean all the components that you have dismantled. Clean the oil filter and the oil tank from the solid sediments. The models PN 106, are provided with a side oil tank; be careful to the maximum tight torque of the oil filter plug. Maximum torque: 10Nm.

• The front bearing has been greased during pump's assembling. Lubrication of said bearing is necessary after long working periods only (for example, normal duration of a set of vanes). It is consequently suggested to pump carefully new grease through the lubrication nipple in order to avoid damages to the seals.

- Procedure for tightening the self-locking flanged nut on the rotor:
  - Fasten the decompressor to a bench or to the machine frame.
  - Fit the feather key and flange on the rotor. Use a pad and a hammer to put the half-joint fully into place correctly.
  - Fully tighten the nut by hand.
  - Lock the rotor rotation.
  - Start tightening the nut with a suitably calibrated torque wrench: 100 Nm for M20X15 nut (PN23-33); 250Nm for M24X2 nut (PN45-...-106).
  - For final tightening, use a torque wrench set at 160 Nm for M20X15 nut (PN23-33) and 350Nm for M24X2 nut (PN45- ... - 106).
  - Carry out a continuous movement of about 30° without interruptions until the nut stops when the wrench clicks at the set torque.

### Mounting the hydraulic drive

- We recommend the drive coupling be oiled when vanes are being replaced.
- However lubricate the drive coupling every 1500 hours.



**We recommend the drive coupling be oiled every 1500 hours.**

- Apply coupling hub to vacuum pump axis respecting the position marked during disassembly: the grain must go back into the seat on the rim.
- Mount the coupling and lubricate internally with NLGI 2 Lithium grease. Provide an adequate quantity of fat, in order to have a medium filling.
- Reassembly the motor without forcing onto the seals.

### Adjusting the self-lubricating pump

- Only for decompressors equipped with automatic lubrication pump.
- The automatic lubricating pump is adjusted by the manufacturer before the shipping.
- If consumption noticeably differs from the indicated value, adjust it as follows:
  - Remove the upper protection cover;
  - Using a screwdriver and a 10 mm wrench, adjust the adjusting screw (K). Close the nut and remount the upper protection cover;
  - It is advisable to turn the screw of ¼ of turn and verify the actual consumption.

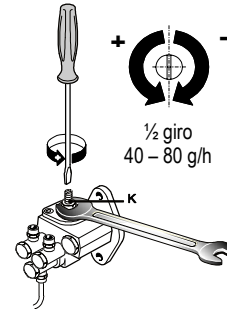

Pic. 6.9



**Do not reduce oil consumption below the value indicated in par. 2.2 (for functioning at speeds different from the maximum, flow is proportionate to rotating speed).**

- ½ turn of the adjusting screw causes a variation in the flow of approximately 40 - 80 g/h, depending on using conditions.

### Cleaning of the inside exhaust port of the pump housing

- Frequency: at every changing of the vanes.
- How to proceed: dismantle the manifold and remove possible oilscales or other foreign parts.
  - The clogging-up of this manifold and the exhaust port depends mainly from heavy duty use of the pump and causes an increase of temperature and a non-perfect closing of the check valve. A careful cleaning of all components, including the insides of the housing and the non-return check valve and its seat, is therefore strongly recommended.

## 7. Malfunctions: troubleshooting

### PROBLEMS

#### Overheating

Cause	Solution
• Faulty lubrication	• Check the oil pump
• Missing oil	• Fill up the oil tank
• Revolutions too high	• Reduce the speed
• Operating time too long at too high vacuum rate	• Decrease the vacuum rate
• Insufficient diameter of vacuum and discharge line	• Check the correct dimensions of the line (minimum suggested DN60)

#### The pump is blocked

Cause	Solution
• Broken vanes: - due to foreign parts - due to faulty lubrication	• Dismantle the pump and change the vanes • Check/clean the filters and elements on the vacuum line • Check the lubrication pump
• Damaged drive system	• Change the damaged parts
• Frozen up pump	• Warm-up the pump

#### Reduced performances

Cause	Solution
• 4-way valve handle in neutral position	• Move the handle against the resting pin
• Worn vanes	• Change the vanes
• Leaking check valve	• Clean the check valve
• Worn O-rings	• Change the seals
• Leaking gaskets and/or valves on the vacuum tank	• Change that damaged parts
• Clogged connecting pipeline	• Change the damaged hoses - pipes
• Floating ball or air filter obstructed	• Dismantle and clean
• Crusted up exhaust manifold	• Dismantle and clean
• Vacuum line components under-dimensioned	• Check the dimensioning for the pump model at hand
• Rubber connection obstructed or damaged	• Change the connections

#### Abnormal oil consumption

Cause	Solution
• Drip-oiler/s badly adjusted	• Adjustment as described
• Oiler's pin not sealing	• Clean the related seat

## 8. Scrapping

- Recycling materials allow reducing the environmental impact and respecting the environment.
- Before scrapping the machine, the following materials need to be separated and suitably disposed of.



**Do not dispose of in the environment. Dispose of in compliance with the standards in force.**

Material	Cast Iron	Steel	Alluminum	Copper	Bronze	Rubber	Vane	Oil	Plastic
PN 23	83	14	0,4	0,4	0,2	0,2	0,6	0,7	0,8
PN 33	84	13	0,3	0,3	0,2	0,2	0,7	0,6	0,7
PN 45	85	12	0,6	0,4	0,1	0,2	0,5	0,5	0,5
PN 58	86	12	0,6	0,3	0,1	0,1	0,6	0,4	0,4
PN 84	86	12	0,5	0,3	0,1	0,1	0,7	0,4	0,4
PN 106	87	11	0,4	0,3	0,1	0,1	0,9	0,3	0,3

## 9. Accessories

### Silencers / Oil separators

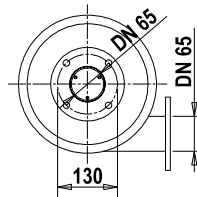
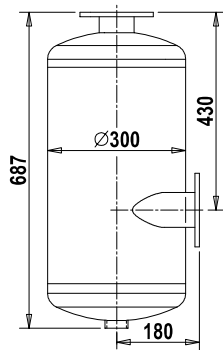
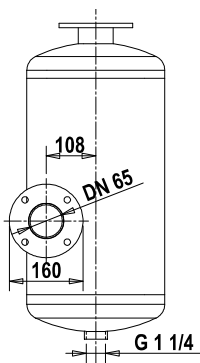

MODEL	PN 23-33-45-58-84
TYPE	DISCHARGE
CODE	15470 043 00
MAX FLOW	540 m <sup>3</sup> /h
OIL TRAP	3,8 l
WEIGHT	27 kg

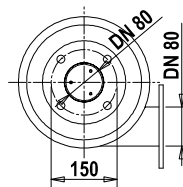
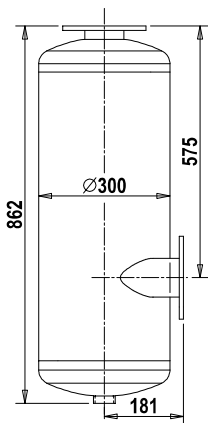
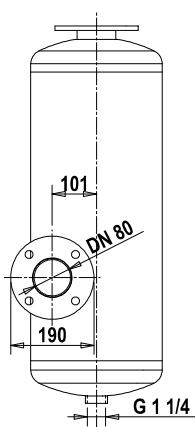

MODEL	PN 106
TYPE	DISCHARGE
CODE	15470 D2C B0
MAX FLOW	912 m <sup>3</sup> /h
OIL TRAP	4,4 l
WEIGHT	35 kg

**Note:** Direct the silencer discharge output away from the silencer suction inlet in order to prevent the input of hot fluids into the injection inlet.



**PN 23-33 DIRECT TRANSMISSION**

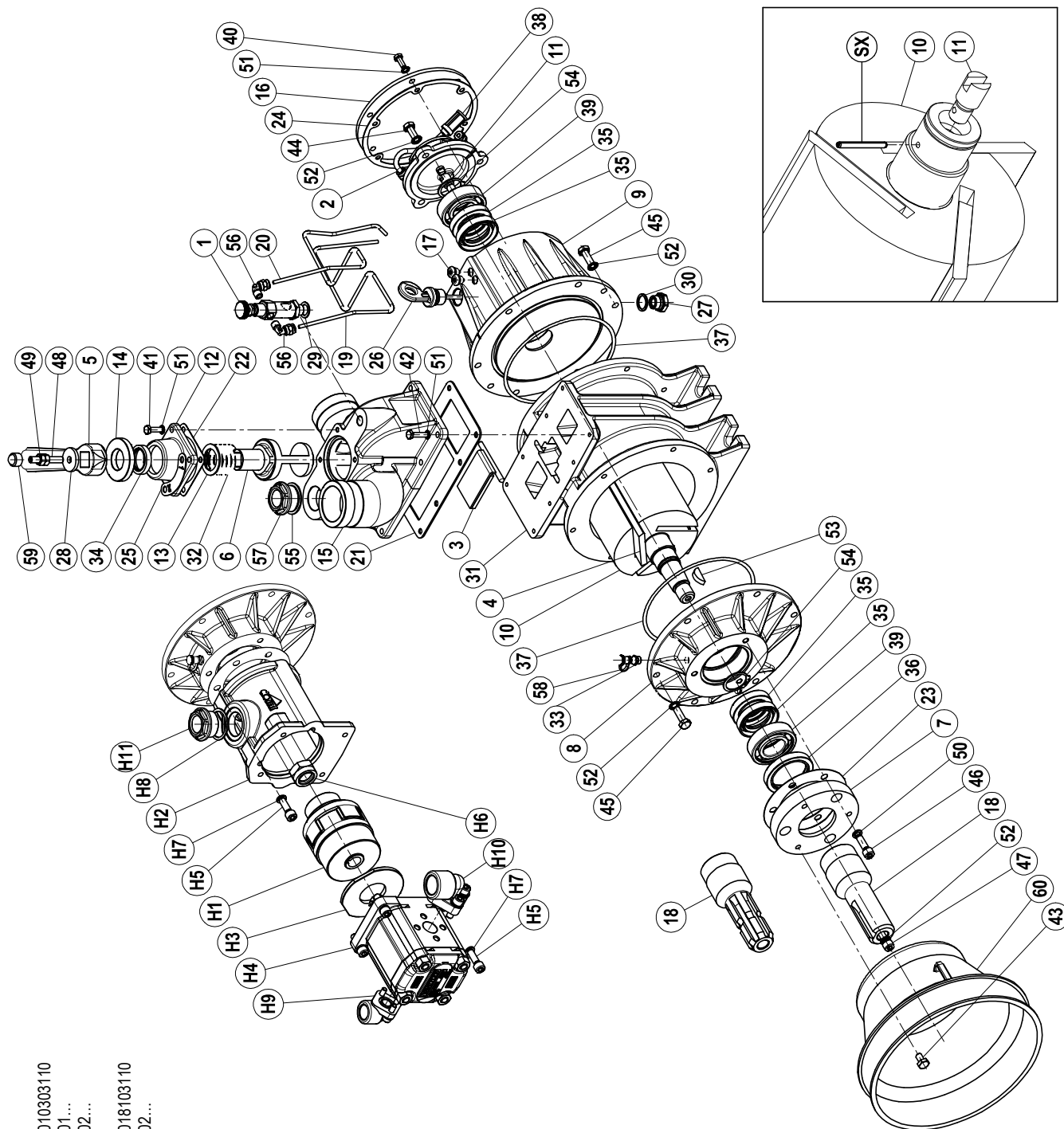

PICTURE SHOWS  
PN 23 PD SMC. SHAFT  
PN 23 PD  
PN 33 PD  
PN 23 HDR  
PN 33 HDR

COD. A010303110  
COD. A01...  
COD. A02...  
COD. E018103110  
COD. E02...

## PN 23-33 D

Pos.	Code	Description	Q.ty	Pos.	Code	Description	Q.ty
1	1401200400	OIL DRIPPER (manual regulation)	1	44	4026102806	SCREW TE 8.8 M8X20 ZINC.	3
2	1407202300	OIL PUMP (RIGHT)	1	45	4026102807	SCREW TE 8.8 M8X25 ZINC.	12
	1407202400	OIL PUMP (LEFT)	1	46	4026121407	SCREW TCEI 8.8 M8X25 ZINC.	3
3	1593600100	NON-RETURN VALVE	1	47	4026121413	SCREW TCEI 8.8 M8X90 ZINC.	1
4	1601600000	VANE PN23 BAKELITE	3	48	4026135415	GRUB SCREW 14.9 M8X50 ZINC.	1
	1601604500	VANE PN23 KEWLAR (on request)	3	49	4026308005	NUT M8 ZINC.	2
	1601600200	VANE PN33 BAKELITE	3	50	4026350505	WASHER GROWER 8 ZINC.	3
	1601604600	VANE PN33 KEWLAR (on request)	3	51	4026351504	WASHER 6 ZINC.	18
5	1605500000	HANDLE	1	52	4026351505	WASHER M8 ZINC.	16
6	1608501300	COVEYOR	1	53	4026500018	TAB 6X10	1
7	1610500900	FLANGE	1	54	4026510025	SEEGER E 30	2
8	1610504000	FRONT FLANGE	1	55	4026702706	WASHER 1"	1
9	1612501200	REAR OIL TANK	1	56	4026706000	FITTING 90° 4X1/8	2
10	1621501600	ROTOR PN23 RIGHT	1	57	4026904003	PLUG 1" ZINC.	1
	1621502600	ROTOR PN23 LEFT	1	58	4029602700	GREASER CAP	1
	1621501700	ROTOR PN33 RIGHT	1	59	4029602701	NUT M8 CAP	1
	1621502700	ROTOR PN33 LEFT	1	60	4029602806	DRIVE SHAFT PROTECTION	1
11	1622002600	SHAFT	1				
12	1623500500	MANIFOLD CAP	1	SX	4026414614	PIN 3X30 (only for left model)	1
13	162409YKBO	SPACER	1				
14	16242003EO	SPACER	1		1892003700	GAKET KIT PN 23-33 D	1
15	1627501600	MANIFOLD	1				
16	1640100000	OIL TANK COVER	1			<b>HYDRAULIC TRANSMISSION</b>	
17	1642600000	PIPLINE PROTECTION	2	H1	1470101600	COUPLING	1
18	1650000500	FRONT SMOOTH SHAFT	1	H2	1612504900	HYDRAULIC BRACKET	1
	1650000400	FRONT SPLINED SHAFT 1"3/8	1	H3	1684002100	SEAL RING	1
19	1663014300	PN 23 SUCTION PIPE D. RIGHT / M. LEFT	1	H4	4024107206	HYDRAULIC MOTOR (RIGHT)	1
	1663024700	PN 23 SUCTION PIPE D. LEFT / M. RIGHT	1		4024107406	HYDRAULIC MOTOR (LEFT)	1
	1663014400	PN 33 SUCTION PIPE D. RIGHT / M. LEFT	1	H5	4026121407	SCREW TCEI 8.8 M8X25 ZINC.	7
	1663024800	PN 33 SUCTION PIPE D. LEFT / M. RIGHT	1	H6	4026305612	NUT M 20X1,5 SELF-BLOCKING	1
20	1663014500	PN 23 DELIVERY D. RIGHT / M. LEFT	1	H7	4026350505	WASHER GROWER 8 ZINC.	7
	1663024500	PN 23 DELIVERY D. LEFT / M. RIGHT	1	H8	4026359001	WASHER 33,5X40X1,5	1
	1663014600	PN 33 DELIVERY D. RIGHT / M. LEFT	1	H9	4026710013	FITTING EG3 EA FG 1/2" RG30/12	1
	1663024600	PN 33 DELIVERY D. LEFT / M. RIGHT	1	H10	4026710015	FITTING EG3 EB FG 3/4 RG40/34	1
21	1680600400	MANIFOLD GASKET	1	H11	4026904003	PLUG 1" ZINC.	1
22	1680700800	MANIFOLD CAP GASKET	1				
23	1680701000	FLANGE GASKET	1				
24	1680712100	OIL TANK GASKET	1				
25	1681005200	PLATE	1				
26	1683600100	OIL STICK	1				
27	1684000000	DRAIN PLUG 3/8	1				
28	1685002800	WASHER 30X8,5 ZINC.	1				
29	1685100000	WASHER 14X20X1,5	1				
30	1685100200	WASHER 17X22X1,5	1				
31	1687502600	PN 23 HOUSING	1				
	1687502700	PN 33 HOUSING	1				
32	1691000200	SPRING	1				
33	4022100010	GREASER M10X1	1				
34	4022200005	SEAL 37X27X7	1				
35	4022200025	SEAL 55X35X10	4				
36	4022200037	SEAL 65X48X10	1				
37	4022200230	O-RING 4575	4				
38	4022300001	NYLON FILTER	1				
39	4023100018	BEARING 6206	2				
40	4026102704	SCREW TE 8.8 M6X16 ZINC.	6				
41	4026102706	SCREW TE 8.8 M6X20 ZINC.	4				
42	4026102707	SCREW TE 8.8 M6X25 ZINC.	8				
43	4026102802	SCREW TE 8.8 M8X12 ZINC.	3				



**PN 23-33 WITH GEARBOX**

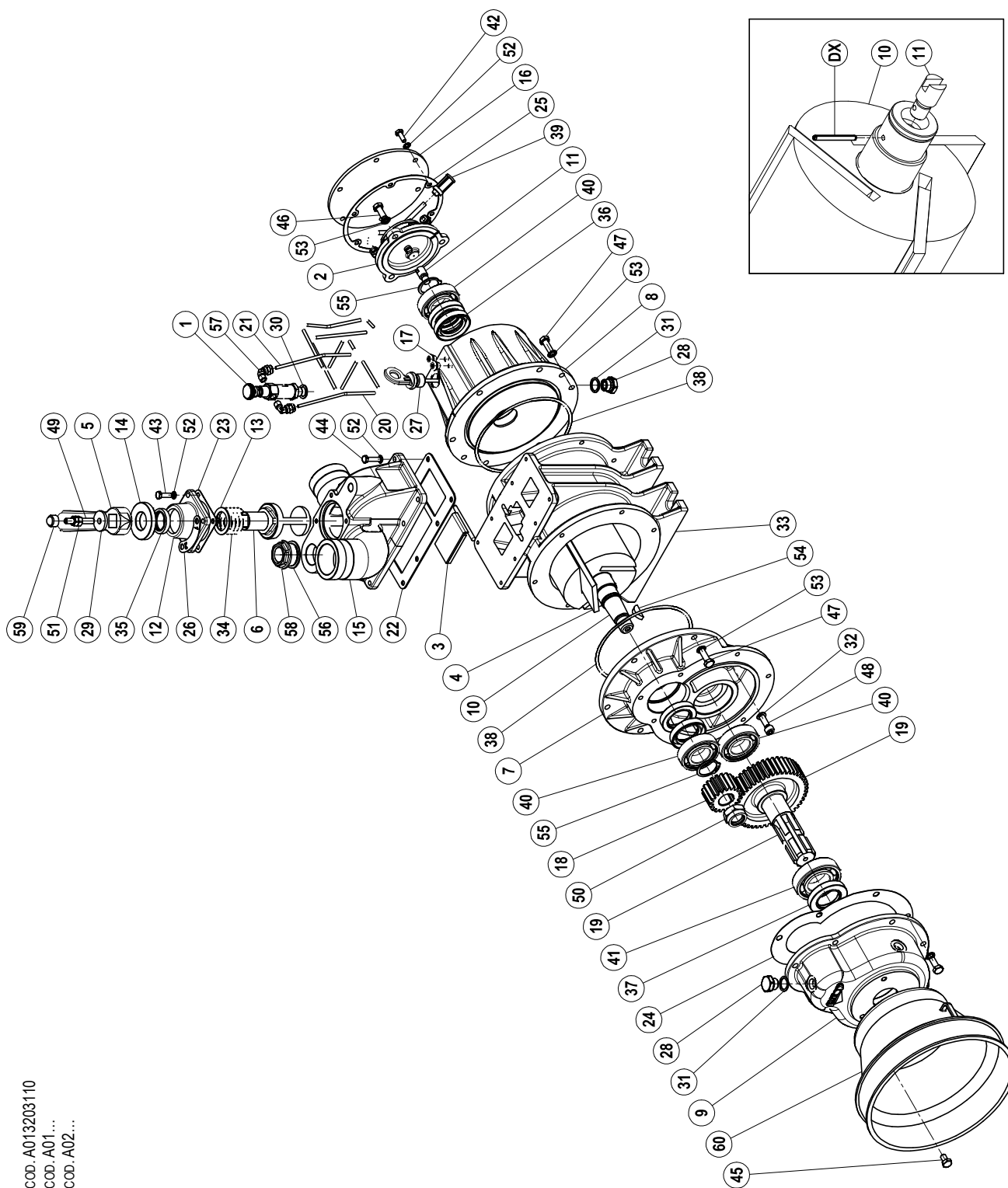

COD. A013203110  
COD. A01...  
COD. A02...

PICTURE SHOWS  
PN 23 M  
PN 23 M  
PN 33 M

**PN 23-33 M**

Pos.	Codice	Descrizione	Q.tà	Pos.	Codice	Descrizione	Q.tà
1	1401200400	OIL DRIPPER (manual regulation)	1	45	4026102802	SCREW TE 8.8 M8X12 ZINC.	3
2	1407202300	OIL PUMP (RIGHT)	1	46	4026102806	SCREW TE 8.8 M8X20 ZINC.	10
	1407202400	OIL PUMP (LEFT)	1	47	4026102807	SCREW TE 8.8 M8X25 ZINC.	10
3	1593600100	NON-RETURN VALVE	1	48	4026121407	SCREW TCEI 8.8 M8X25 ZINC.	2
4	1601600000	VANE PN23 BAKELITE	3	49	4026135415	GRUB SCREW 14.9 M8X50 ZINC.	1
	1601604500	VANE PN23 KEVLAR (on request)	3	50	4026305612	NUT M 20X1,5 SELF-BLOCKING	1
	1601600200	VANE PN33 BAKELITE	3	51	4026308005	NUT M8 ZINC.	2
	1601604600	VANE PN33 KEVLAR (on request)	3	52	4026351504	WASHER M 6 ZINC.	18
5	1605500000	HANDLE	1	53	4026351505	WASHER M 8 ZINC.	20
6	1608501300	CONVEYOR	1	54	4026500018	TAB 6X10	1
7	1610503900	GEARBOX FLANGE	1	55	4026510025	SEEGER E 30	2
8	1612501200	REAR OIL TANK	1	56	4026702706	WASHER 1"	1
9	1612501300	GEAR BOX	1	57	4026706000	FITTING 4X1/8 90°	2
10	1621501600	ROTOR PN23 RIGHT	1	58	4026904003	PLUG 1" ZINC.	1
	1621502600	ROTOR PN23 LEFT	1	59	4029602701	NUT M8 CAP	1
	1621501700	ROTOR PN33 RIGHT	1	60	4029602806	DRIVE SHAFT PROTECTION	1
	1621502700	ROTOR PN33 LEFT	1				
11	1622002600	SHAFT	1	DX	4026414614	PIN 3X30 (only for right model)	1
12	1623500500	MANIFOLD CAP	1				
13	162409YKBO	SPACER	1		1892000100	GASKET KIT PN 23-33 M	1
14	16242003EO	SPACER	1				
15	1627501600	MANIFOLD	1				
16	1640100000	OIL TANK COVER	1				
17	1642600000	PIPELINE PROTECTION	2				
18	1651000200	PINION	1				
19	1651000300	GEAR	1				
20	1663014300	PN23 SUCTION PIPE D RIGHT / M LEFT	1				
	1663024700	PN23 SUCTION PIPE D LEFT / M RIGHT	1				
	1663014400	PN33 SUCTION PIPE D RIGHT / M LEFT	1				
	1663024800	PN33 SUCTION PIPE D LEFT / M RIGHT	1				
21	1663014500	PN23 DELIVERY PIPE D RIGHT / M LEFT	1				
	1663024500	PN23 DELIVERY PIPE D LEFT / M RIGHT	1				
	1663014600	PN33 DELIVERY PIPE D RIGHT / M LEFT	1				
	1663024600	PN33 DELIVERY PIPE D LEFT / M RIGHT	1				
22	1680600400	MANIFOLD GAKET	1				
23	1680700800	MANIFOLD CAP GASKET	1				
24	1680700900	GASKET	1				
25	1680712100	OIL TANK GASKET	1				
26	1681005200	PLATE	1				
27	1683600100	OIL STICK	1				
28	1684000000	DRAIN PLUG 3/8	4				
29	1685002800	WASHER FE 30X8,5 ZINC.	1				
30	1685100000	OIL DRIPPER WASHER 14X20X1,5	1				
31	1685100200	WASHER 17X22X1,5	4				
32	1685100800	WASHER 8X14X1,5	2				
33	1687502600	PN 23 HOUSING	1				
	1687502700	PN 33 HOUSING	1				
34	1691000200	SPRING	1				
35	4022200005	SEAL 37X27X7	1				
36	4022200025	SEAL 55X35X10	4				
37	4022200032	SEAL 60X35X10	1				
38	4022200230	O-RING 4575	4				
39	4022300001	NYLON FILTER	1				
40	4023100018	BEARING 6206	3				
41	4023100020	BEARING 6207	1				
42	4026102704	SCREW TE 8.8 M6X16 ZINC.	6				
43	4026102706	SCREW TE 8.8 M6X20 ZINC.	4				
44	4026102707	SCREW TE 8.8 M6X25 ZINC.	8				

**PN 45-58-84 DIRECT TRANSMISSION**

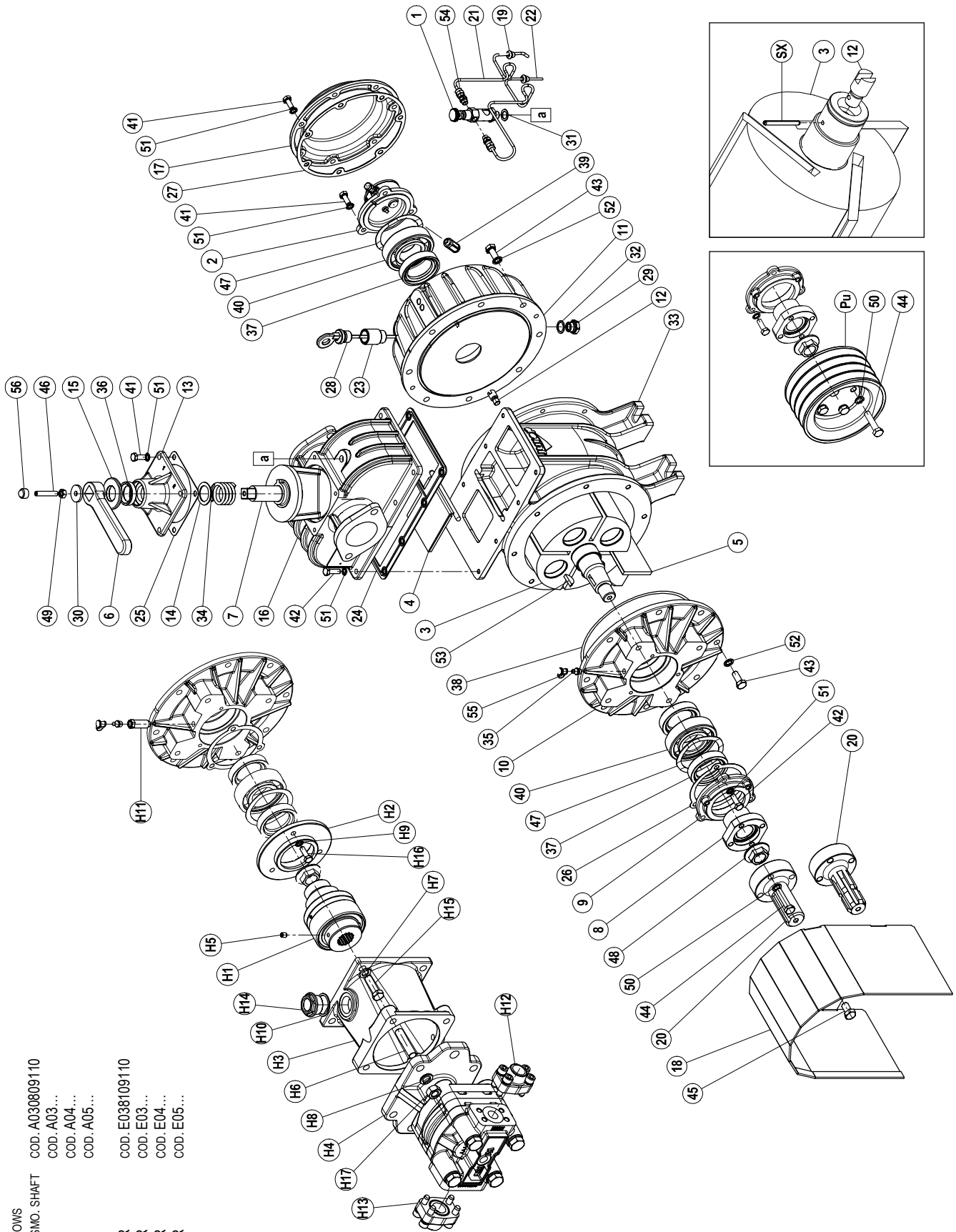

- PICTURE SHOWS
- PN 45 PD SMO. SHAFT COD. A030809110
  - PN 45 PD COD. A03...
  - PN 58 PD COD. A04...
  - PN 84 PD COD. A05...
  - PN 45 HDR COD. E038109110
  - PN 45 HDR COD. E03...
  - PN 58 HDR COD. E04...
  - PN 84 HDR COD. E05...

**PN 45-58-84 D**

Pos.	Code	Description	Q.ty	Pos.	Code	Description	Q.ty
1	1401200400	OIL DRIPPER (manual regulation)	1	41	4026102806	SCREW TE 8.8 M8X20 ZINC.	14
2	1407200500	OIL PUMP (right)	1	42	4026102807	SCREW TE 8.8 M8X25 ZINC.	11
	1407202100	OIL PUMP (left)	1	43	4026102907	SCREW TE 8.8 M10X25 ZINC.	16
3	1521500200	ROTOR PN 45	1	44	4026102911	SCREW TE 8.8 M10X45 ZINC.	4
	1521500300	ROTOR PN 58	1	45	4026103000	SCREW TE 8.8 M12X20 ZINC.	4
	1521500400	ROTOR PN 84	1	46	4026135415	GRUB SCREW 14.9 M8X50	1
4	1593600000	NON-RETURN VALVE	1	47	4026300020	COMPENSATION RING	2
5	1601600400	VANE PN 45 BAKELITE	4	48	4026305614	SELF-BLOCKING NUT M24X2	1
	1601600600	VANE PN 58 BAKELITE	4	49	4026308005	NUT M8 ZINC.	2
	1601600800	VANE PN 84 BAKELITE	4	50	4026350708	WASHER GROWER 10 ZINC.	4
6	1605500000	HANDLE	1	51	4026351505	WASHER M8 ZINC.	25
7	1608500000	CONVEYOR	1	52	4026351506	WASHER M10 ZINC.	16
8	1610006600	TRANSMISSION FLANGE	1	53	4026500018	TAB 6X10	1
9	1610500400	FRONT OIL SEAL FLANGE	1	54	4026702000	FITTING 4X1/8	2
10	1610500500	FLANGE (DIRECT TRANSMISSION)	1	55	4029602700	GREASER CAP	1
11	1612500300	REAR OIL TANK	1	56	4029602701	NUT M8 CAP	2
12	1622002600	SHAFT	1				
13	1623100000	MANIFOLD CAP	1	SX	4026414614	PIN 3X30 (only for left model)	1
14	162409YKB0	SPACER	1				
15	1624202300	SPACER	1		1892001000	GASKET KIT PN 45-58-84 PD	1
16	1627500000	MANIFOLD	1				
17	1640101100	OIL TANK COVER	1			<b>HYDRAULIC TRANSMISSION</b>	
18	1642003000	DRIVE SHAFT PROTECTION	1	H1	1470100400	COUPLING	1
19	1642600000	PIPELINE PROTECTION	2	H2	1610005500	TRANSMISSION FLANGE	1
20	1650004300	SMOOTH SHAFT	1	H3	1612501400	HYDRAULIC BRACKET	1
	1650004700	SPLINED SHAFT 1"3/8	1	H4	4024107009	HYDRAULIC MOTOR PN 45	1
21	1663005100	DELIVERY PIPE PN 45 D RIGHT / M LEFT	1		4024107008	HYDRAULIC MOTOR PN 58	1
	1663005500	DELIVERY PIPE PN 45 D LEFT / M RIGHT	1		4024107005	HYDRAULIC MOTOR PN 84	1
	1663005200	DELIVERY PIPE PN 58 D RIGHT / M LEFT	1	H5	4026136005	GRUB SCREW 14.9 M8X12	1
	1663005600	DELIVERY PIPE PN 58 D LEFT / M RIGHT	1	H6	4026171304	STUD SCREW 8.8 M14X40	4
	1663005300	DELIVERY PIPE PN 84 D RIGHT / M LEFT	1	H7	4026350709	WASHER GROWER 12 ZINC.	2
	1663005700	DELIVERY PIPE PN 84 D LEFT / M RIGHT	1	H8	4026350710	WASHER GROWER 14 ZINC.	4
22	1663011800	SUCTION PIPE PN 45 D RIGHT / M LEFT	1	H9	4026351505	WASHER M 8 ZINC.	3
	1663011900	SUCTION PIPE PN 45 D LEFT / M RIGHT	1	H10	4026359001	WASHER 33,5X40X1,5	1
	1663010400	SUCTION PIPE PN 58 D RIGHT / M LEFT	1	H11	4026705001	FITTING	1
	1663012000	SUCTION PIPE PN 58 D LEFT / M RIGHT	1	H12	4026711001	AFS 100G 3/4 FLANGE (PN 45)	1
	1663010300	SUCTION PIPE PN 84 D RIGHT / M LEFT	1		4026711002	ASF 102G 1" FLANGE (PN 58)	1
	1663012100	SUCTION PIPE PN 84 D LEFT / M RIGHT	1		4026711003	ASF 104G 1"1/4 FLANGE (PN 84)	1
23	1673004100	OIL STICK COUPLING	1	H13	4026711002	ASF 102G 1" FLANGE (PN 45)	1
24	1680600100	MANIFOLD GASKET	1		4026711003	ASF 104G 1"1/4 FLANGE (PN 58)	1
25	1680700200	COVER GASKET	1		4026711004	AFS 106G 1"1/2 FLANGE (PN 84)	1
26	1680700400	FLANGE GASKET	1	H14	4026904003	PLUG 1" ZINC.	1
27	1680707500	OIL TANK COVER GASKET	1	H15	4026103004	SCREW TE 8.8 M12X40 ZINC.	2
28	1683600300	OIL STICK	1	H16	4026102807	SCREW TE 8.8 M8X25 ZINC.	3
29	1684000000	DRAIN PLUG 3/8	1	H17	4026308008	NUT M14 ZINC.	4
30	1685002800	WASHER 30X8,5 ZINC.	1			<b>BELT DRIVE</b>	
31	1685100000	DRIPPER WASHER 14X20X1,5	1	Pu	1653501000	BELT SPB 150X4 GROOVES	1
32	1685100200	WASHER 17X22X1,5	1				
33	1687500200	PN 45 HOUSING	1	44	4026102911	SCREW TE 8.8 M10X45 ZINC.	4
	1687500300	PN 58 HOUSING	1	50	4026350708	WASHER GROWER 10 ZINC.	4
	1687500400	PN 84 HOUSING	1				
34	1691000000	SPRING	1				
35	4022100010	GREASER M10X1	1				
36	4022200030	SEAL 41X27X10	1				
37	4022200110	SEAL 72X48X15	3				
38	4022200240	O-RING 4825	2				
39	4022300001	NYLON FILTER	1				
40	4023100040	BEARING 6308	2				

**PN 45-58-84 WITH GEARBOX**

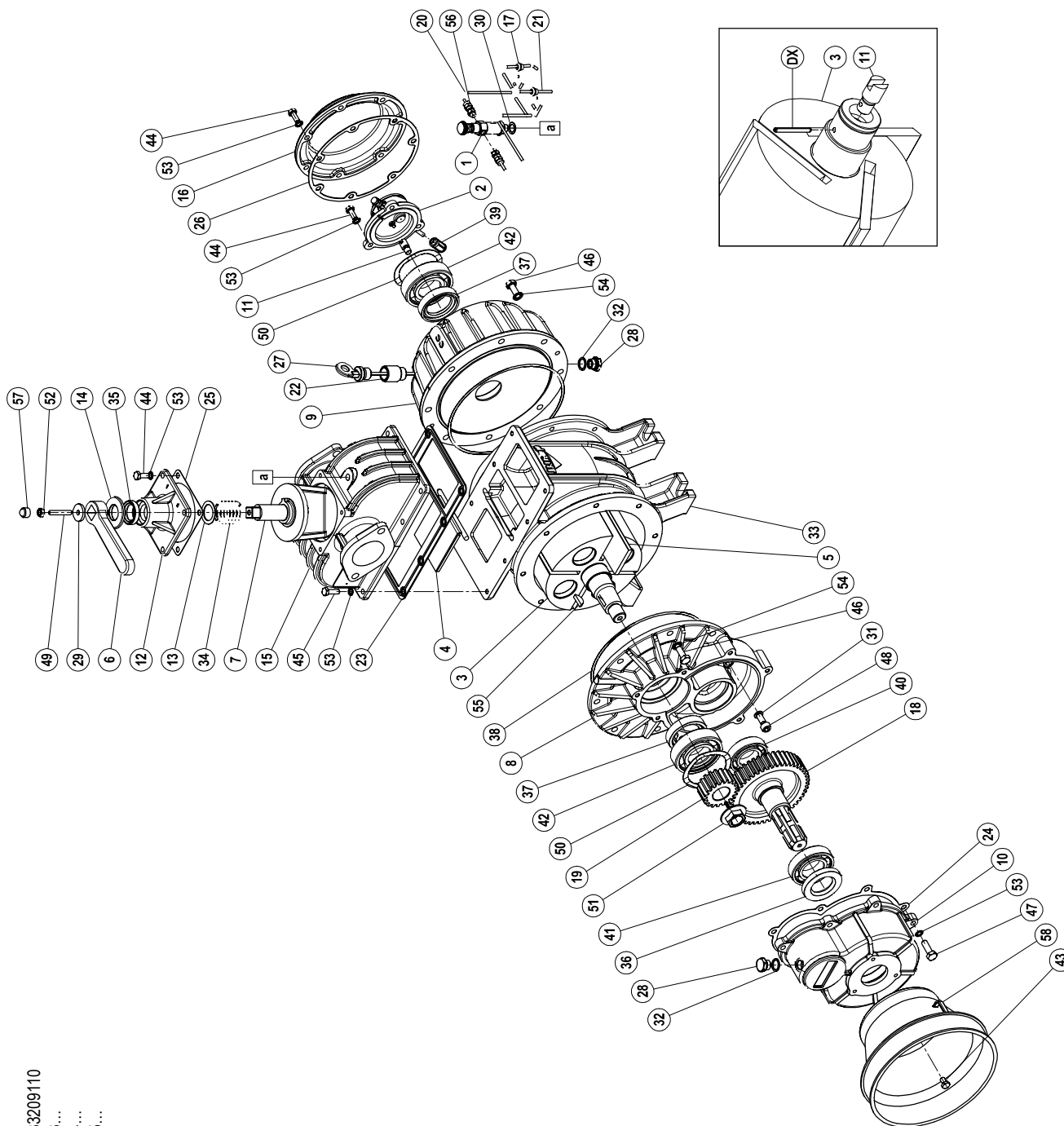

COD. A033209110  
COD. A03...  
COD. A04...  
COD. A05...

PICTURE SHOWS  
PN 45 M  
PN 45 M  
PN 58 M  
PN 84 M

**PN 45-58-84 M**

Pos.	Code	Description	Q.ty	Pos.	Code	Description	Q.ty
1	1401200400	OIL DRIPPER (manual regulation)	1	42	4023100040	BEARING6308	2
2	1407200500	OIL PUMP (right)	1	43	4026102802	SCREW TE 8.8 M8X12 ZINC.	3
	1407202100	OIL PUMP (left)	1	44	4026102806	SCREW TE 8.8 M8X20 ZINC.	14
3	1521500200	ROTOR PN 45	1	45	4026102807	SCREW TE 8.8 M8X25 ZINC.	8
	1521500300	ROTOR PN 58	1	46	4026102907	SCREW TE 8.8 M10X25 ZINC.	12
	1521500400	ROTOR PN 84	1	47	4026102808	SCREW TE 8.8 M8X30 ZINC.	7
4	1593600000	NON-RETURN VALVE	1	48	4026121808	SCREW TCEI 8.8 M10X25 ZINC.	2
5	1601600400	VANE PN 45 BAKELITE	4	49	4026135415	GRAB SCREW 14.9 M8X50 ZINC.	1
	1601600600	VANE PN 58 BAKELITE	4	50	4026300020	COMPENSATION RING	2
	1601600800	VANE PN 84 BAKELITE	4	51	4026305614	SELF-BLOCKING NUT M24X2	1
6	1605500000	HANDLE	1	52	4026308005	NUT M8 ZINC.	2
7	1608500000	CONVEYOR	1	53	4026351505	WASHER M8 ZINC.	29
8	1610500000	GEARBOX FLANGE	1	54	4026351506	WASHER M10 ZINC.	12
9	1612500300	REAR OIL TANK	1	55	4026500018	TAB 6X10	1
10	1612503100	GEARBOX	1	56	4026702000	FITTING 4X1/8	2
11	1622002600	SHAFT	1	57	4029602701	NUT M8 CAP	1
12	1623100000	MANIFOLD CAP	1	58	4029602806	DRIVE SHAFT PROTECTION	1
13	162409YKBO	SPACER	1				
14	1624202300	SPACER	1	DX	4026414614	PIN 3X30 (only right model)	1
15	1627500000	MANIFOLD	1				
16	1640101100	OIL TANK COVER	1		1892000000	GASKET KIT PN 45-58-84 M	1
17	1642600000	PIPELINE PROTECTION	1				
18	1651000000	GEAR	1				
19	1651000100	PINION	1				
20	1663005100	DELIVERY PIPE PN 45 D RIGHT / M LEFT	1				
	1663005500	DELIVERY PIPE PN 45 D LEFT / M RIGHT	1				
	1663005200	DELIVERY PIPE PN 58 D RIGHT / M LEFT	1				
	1663005600	DELIVERY PIPE PN 58 D LEFT / M RIGHT	1				
	1663005300	DELIVERY PIPE PN 84 D RIGHT / M LEFT	1				
	1663005700	DELIVERY PIPE PN 84 D LEFT / M RIGHT	1				
21	1663011800	SUCTION PIPE PN 45 D RIGHT / M LEFT	1				
	1663011900	SUCTION PIPE PN 45 D LEFT / M RIGHT	1				
	1663010400	SUCTION PIPE PN 58 D RIGHT / M LEFT	1				
	1663012000	SUCTION PIPE PN 58 D LEFT / M RIGHT	1				
	1663010300	SUCTION PIPE PN 84 D RIGHT / M LEFT	1				
	1663012100	SUCTION PIPE PN 84 D LEFT / M RIGHT	1				
22	1673004100	OIL STICK COUPLING	1				
23	1680600100	MANIFOLD GASKET	1				
24	1680700000	GASKET	1				
25	1680700200	MANIFOLD CAP GASKET	1				
26	1680707500	OIL TANK GASKET	1				
27	1683600300	OIL STICK	1				
28	1684000000	DRAIN PLUG 3/8	4				
29	1685002800	WASHER FE 30X8,5 ZINC.	1				
30	1685100000	DRIPPER WASHER 14X20X1,5	1				
31	1685100100	WASHER 10X16X1,5	2				
32	1685100200	WASHER 17X22X1,5	4				
33	1687500200	PN 45 HOUSING	1				
	1687500300	PN 58 HOUSING	1				
	1687500400	PN 84 HOUSING	1				
34	1691000000	SPRING	1				
35	4022200030	SEAL 41X27X10	1				
36	4022200040	SEAL 72X40X10	1				
37	4022200110	SEAL 72X48X15	2				
38	4022200240	O-RING 4825	2				
39	4022300001	NYLON FILTER	1				
40	4023100020	BEARING 6207	1				
41	4023100030	BEARING 6208	1				



**PN 106 DIRECT TRANSMISSION**

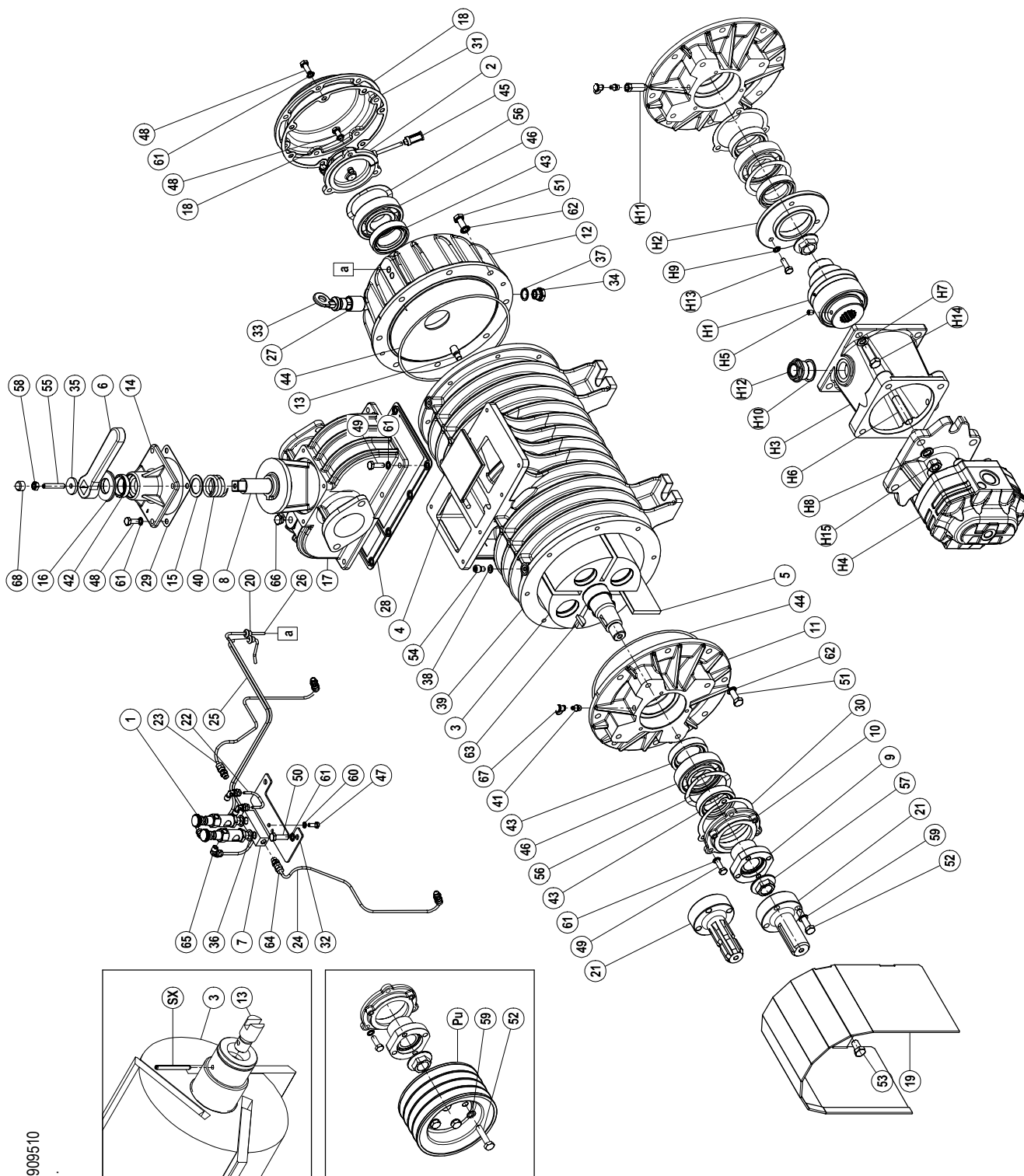

PICTURE SHOWS  
PN 106 PD SMO. SHAFT COD. A060909510  
PN 106 PD COD. A06...

PN 106 HDR COD. E068109510  
PN 106 HDR COD. E06...

## PN 106 D

Pos.	Code	Description	Q.ty	Pos.	Code	Description	Q.ty
1	1401200400	OIL DRIPPER (manual regulation)	2	53	4026103000	SCREW TE 8.8 M12X20 ZINC.	4
2	1407202100	OIL PUMP (left)	1	54	4026121401	SCREW TCEI 8.8 M8X12 ZINC.	2
	1407200500	OIL PUMP (right)	1	55	4026135414	GRUB SCREW 14.9 M8X45 ZINC.	1
3	1521500500	ROTOR	1	56	4026300020	COMPENSATION RING	2
4	1593600000	NON-RETURN VALVE	1	57	4026305614	SELF-BLOCKING NUT M24X2	1
5	1601601000	VANE PN 106	4	58	4026308005	NUT M8 ZINC.	2
6	1605500000	HANDLE	1	59	4026350708	WASHER GROWER 10 ZINC.	4
7	1608100000	DISTRIBUTOR	1	60	4026351504	WASHER M6 ZINC.	2
8	1608500000	CONVEYOR	1	61	4026351505	WASHER M8 ZINC.	25
9	1610006600	TRANSMISSION FLANGE	1	62	4026351506	WASHER M10 ZINC.	16
10	1610500400	FRONT OIL SEAL FLANGE	1	63	4026500018	TAB 6X10	1
11	1610500500	DIRECT TRANSMISSION FLANGE	1	64	4026702000	FITTING 4X1/8	4
12	1612500300	REAR OIL TANK	1	65	4026706000	FITTING 4X1/8 (90°)	4
13	1622002600	SHAFT	1	66	4026905002	PLUG 1/4 ZINC.	1
14	1623100000	MANIFOLD CAP	1	67	4029602700	GREASER CAP	1
15	162409YKBO	SPACER	1	68	4029602701	NUT M8 CAP	1
16	1624202300	SPACER	1				
17	1627500000	MANIFOLD	1	SX	4026414614	PIN 3X30 (only for left model)	1
18	1640101100	OIL TANK COVER	1				
19	1642003000	DRIVE SHAFT PROTECTION	1		1892001000	GASKET KIT PN 106 PD	1
20	1642600000	PIPELINE PROTECTION	2				
21	1650004300	SMOOTH SHAFT	1			<b>HYDRAULIC TRANSMISSION</b>	
	1650004700	SPLINED SHAFT 1"3/8	1	H1	1470100400	COUPLING	1
22	1663011000	LUBRICATION PIPE	1	H2	1610005500	TRANSMISSION FLANGE	1
23	1663018500	LUBRICATION PIPE D LEFT / M RIGHT	1	H3	1612501400	HYDRAULIC BRACKET	1
	1663018600	LUBRICATION PIPE D RIGHT / M LEFT	1	H4	4024107001	HYDRAULIC MOTOR	1
24	1663018600	LUBRICATION PIPELINE D LEFT / M RIGHT	1	H5	4026136005	GRUB SCREW 14.9 M8X12 ZINC.	1
	1663018500	LUBRICATION PIPE D RIGHT / M LEFT	1	H6	4026171304	STUD SCREW 8.8 M14X40 ZINC.	4
25	1663025100	DELIVERY PIPE D LEFT / M RIGHT	1	H7	4026350709	WASHER GROWER 12 ZINC.	2
	1663018400	DELIVERY PIPE D RIGHT / M LEFT	1	H8	4026350710	WASHER GROWER 14 ZINC.	4
26	1663025200	SUCTION PIPE D LEFT / M RIGHT	1	H9	4026351505	WASHER M8 ZINC.	3
	1663018700	SUCTION PIPE D RIGHT / M LEFT	1	H10	4026359001	WASHER 33,5X40X1,5	1
27	1673004100	OIL STICK COUPLING	1	H11	4026705001	FITTING	1
28	1680600100	MANIFOLD GASKET	1	H12	4026904003	PLUG 1" ZINC.	1
29	1680700200	GASKET	1	H13	4026102807	SCREW TE 8.8 M8X25 ZINC.	3
30	1680700400	DIRECT TRANSMISSION FLANGE GASKET	1	H14	4026103004	SCREW TE 8.8 M12X40 ZINC.	2
31	1680707500	OIL TANK COVER GASKET	1	H15	4026308008	NUT M14 ESAG.ZINC.	4
32	1681100100	DISTRIBUTOR BRACKET	1			<b>BELT DRIVE</b>	
33	1683600300	OIL STICK	1				
34	1684000000	DRAIN PLUG 3/8	1	Pu	1653501000	BELT SPB 150X4 GROOVES	1
35	1685002800	WASHER 30X8,5	1	52	4026102911	SCREW TE 8.8 M10X45 ZINC.	4
36	1685100000	DRIPPER WASHER 14X20X1,5	2	59	4026350708	WASHER GROWER 10 ZINC.	4
37	1685100200	WASHER 17X22X1,5	1				
38	1685100800	WASHER 8X14X1,5	2				
39	1687500500	HOUSING PN 106	1				
40	1691000000	SPRING	1				
41	4022100010	GREASER M10X1	1				
42	4022200030	SEAL 41X27X10	1				
43	4022200110	SEAL 72X48X15	3				
44	4022200240	O-RING 4825	2				
45	4022300001	NYLON FILTER	1				
46	4023100040	BEARING 6308	2				
47	4026102704	SCREW TE 8.8 M6X16 ZINC.	2				
48	4026102806	SCREW TE 8.8 M8X20 ZINC.	14				
49	4026102807	SCREW TE 8.8 M8X25 ZINC.	9				
50	4026102808	SCREW TE 8.8 M8X30 ZINC.	2				
51	4026102907	SCREW TE 8.8 M10X25 ZINC.	16				
52	4026102911	SCREW TE 8.8 M10X45 ZINC.	4				



**PN 106 WITH GEARBOX**

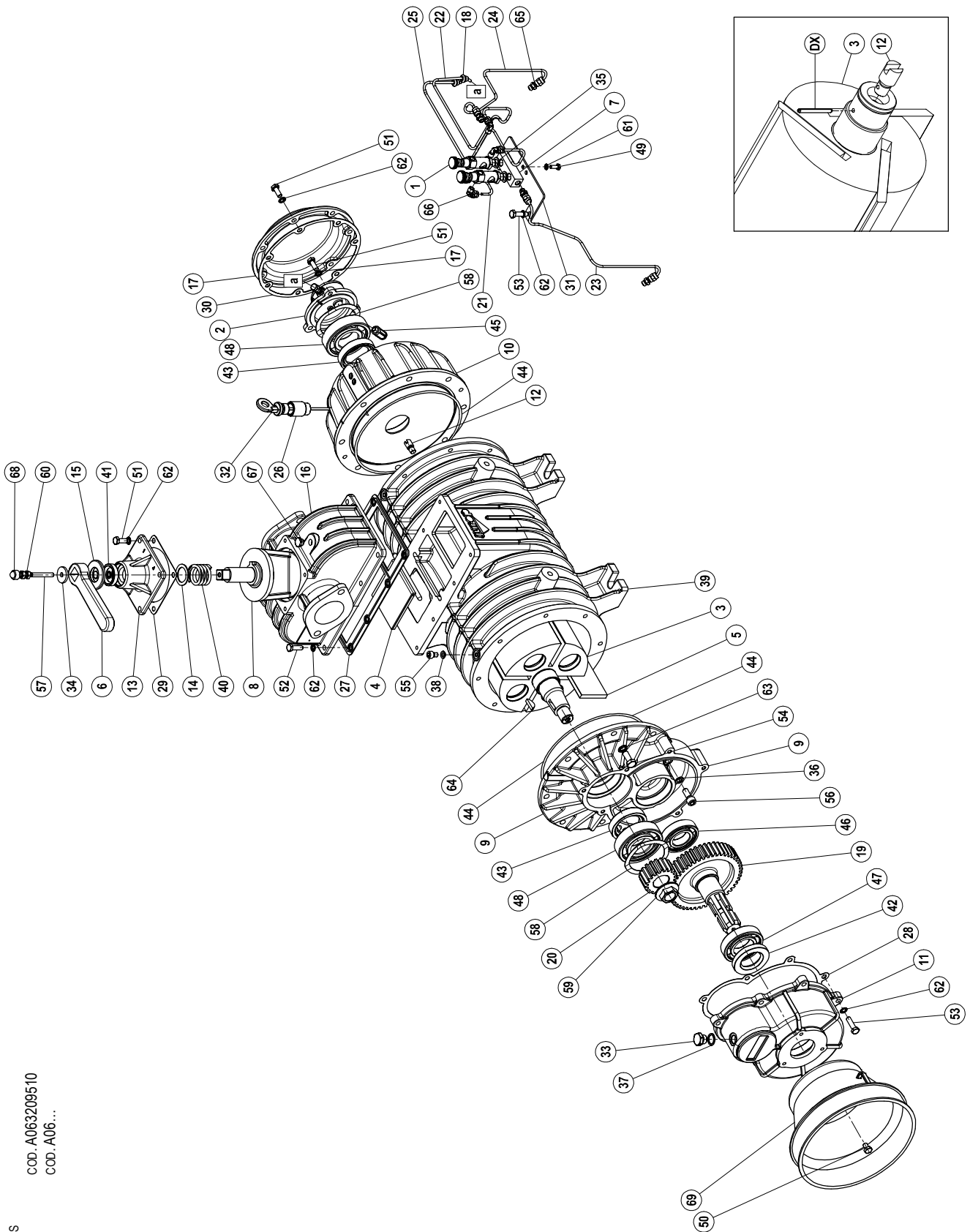

COD. A063209510  
COD. A06...

PICTURE SHOWS  
PN 106 M  
PN 106 M

## PN 106 M

Pos.	Code	Description	Q.ty	Pos.	Code	Description	Q.ty
1	1401200400	OIL DRIPPER (manual regulation)	2	53	4026102808	SCREW TE 8.8 M8X30 ZINC.	9
2	1407200500	OIL PUMP (right)	1	54	4026102907	SCREW TE 8.8 M10X25 ZINC.	14
	1407202100	OIL PUMP (right)	1	55	4026121401	SCREW TCEI 8.8 M8X12 ZINC.	2
3	1521500500	ROTOR	1	56	4026121808	SCREW TCEI 8.8 M10X25 ZINC.	2
4	1593600000	NON-RETURN VALVE	1	57	4026135415	GRUB SCREW 14.9 M8X50	1
5	1601601000	VANE PN 106 (BAKELITE)	4	58	4026300020	COMPENSATION RING	2
6	1605500000	HANDLE	1	59	4026305614	SELF-BLOCKING NUT M24X2	1
7	1608100000	DISTRIBUTOR	1	60	4026308005	NUT M8 ZINC.	2
8	1608500000	CONVEYOR	1	61	4026351504	WASHER M6 ZINC.	2
9	1610500000	GEARBOX FLANGE	1	62	4026351505	WASHER M8 ZINC.	29
10	1612500300	REAR OIL TANK	1	63	4026351506	WASHER M10 ZINC.	14
11	1612503100	GEARBOX	1	64	4026500018	TAB 6X10	1
12	1622002600	SHAFT	1	65	4026702000	FITTING 4X1/8	4
13	1623100000	MANIFOLD CAP	1	66	4026706000	FITTING 4X1/8 (90°)	4
14	162409YKB0	SPACER	1	67	4026905002	PLUG ¼ ZINC.	1
15	1624202300	SPACER	1	68	4029602701	NUT M8 CAP	2
16	1627500000	MANIFOLD	1	69	4029602806	DRIVE SHAFT PROTECTION	1
17	1640101100	OIL TANK COVER	1				
18	1642600000	PIPELINE PROTECTION	2	DX	4026414614	PIN 3X30 (only for right model)	1
19	1651000000	GEAR	1				
20	1651000100	PINION	1		1892000000	GASKET KIT PN 106 M	1
21	1663011000	LUBRICATION PIPELINE	1				
22	1663018400	DELIVERY PIPE D RIGHT / M LEFT	1				
	1663025100	DELIVERY PIPE D LEFT / M RIGHT	1				
23	1663018500	LUBRICATION PIPELINE D RIGHT / M LEFT	1				
	1663018600	LUBRICATION PIPELINE D LEFT / M RIGHT	1				
24	1663018600	LUBRICATION PIPELINE D RIGHT / M LEFT	1				
	1663018500	LUBRICATION PIPELINE D LEFT / M RIGHT	1				
25	1663018700	SUCTION PIPE D RIGHT / M LEFT	1				
	1663025100	SUCTION PIPE D LEFT / M RIGHT	1				
26	1673004100	OIL STICK COUPLING	1				
27	1680600100	MANIFOLD GASKET	1				
28	1680700000	GEARBOX GASKET	1				
29	1680700200	MANIFOLD CAP GASKET	1				
30	1680707500	OIL TANK COVER GASKET	1				
31	1681100100	DISTRIBUTOR BRACKET	1				
32	1683600300	OIL STICK	1				
33	1684000000	DRAIN PLUG 3/8	4				
34	1685002800	WASHER 30X8,5 ZINC.	1				
35	1685100000	OIL DRIPPER WASHER 14X20X1,5	2				
36	1685100100	WASHER 10X16X1,5	2				
37	1685100200	WASHER 17X22X1,5	4				
38	1685100800	WASHER 8X14X1,5	2				
39	1687500500	HOUSING PN 106	1				
40	1691000000	SPRING	1				
41	4022200030	SEAL 41X27X10	1				
42	4022200040	SEAL 72X40X10	1				
43	4022200110	SEAL 72X48X15	2				
44	4022200240	O-RING 4825	2				
45	4022300001	NYLON FILTER	1				
46	4023100020	BEARING 6207	1				
47	4023100030	BEARING 6208	1				
48	4023100040	BEARING 6308	2				
49	4026102704	SCREW TE 8.8 M6X16 ZINC.	2				
50	4026102802	SCREW TE 8.8 M8X12 ZINC.	2				
51	4026102806	SCREW TE 8.8 M8X20 ZINC.	14				
52	4026102807	SCREW TE 8.8 M8X25 ZINC.	6				

**PN 106 WITH SIDE OIL TANK AND GEARBOX (1000 RPM)**

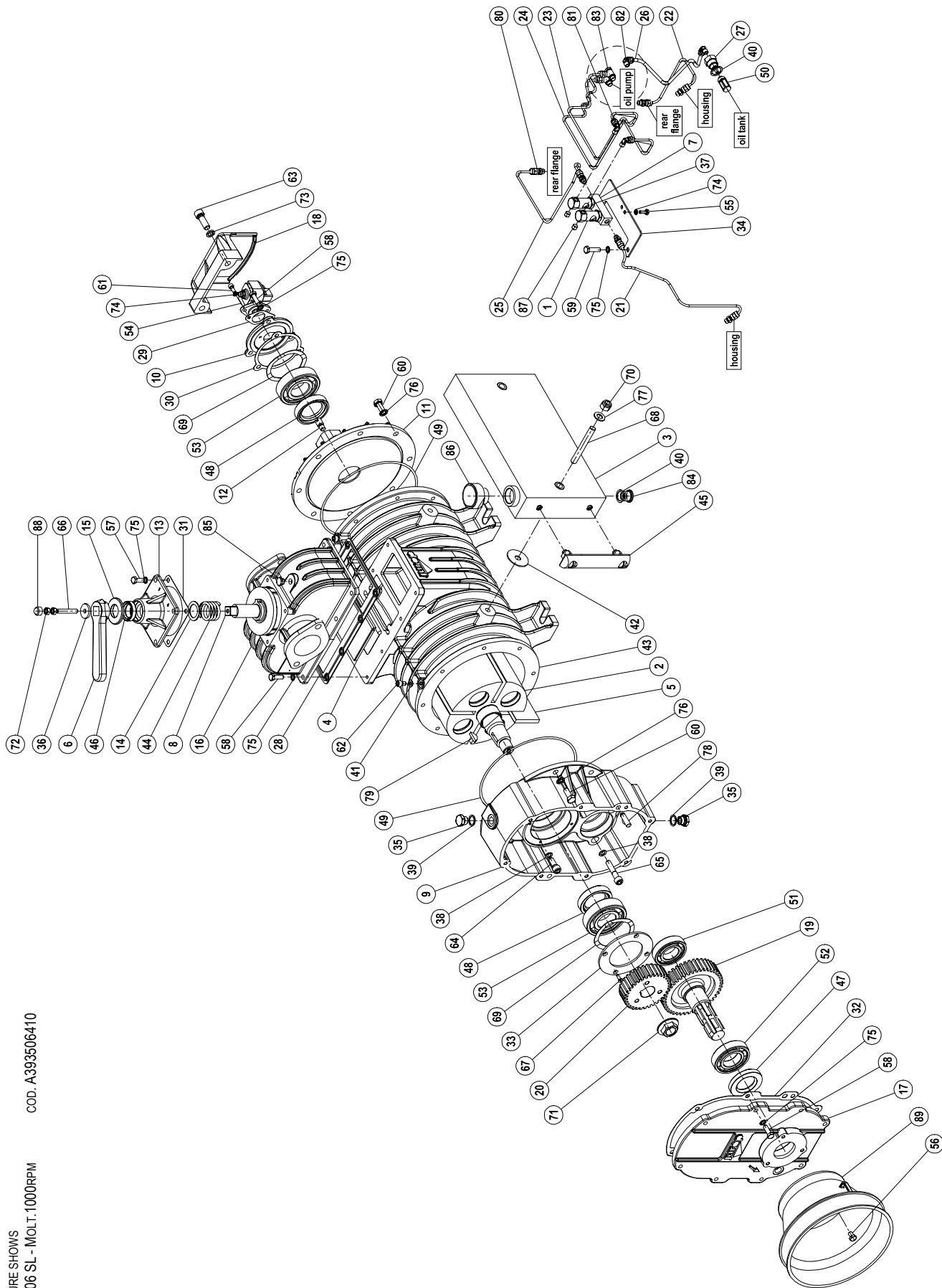

PICTURE SHOWS  
PN 106 SL - MOLT. 1000RPM  
COD. A393506410

**PN 106 with side oil tank and gearbox (1000 rpm)**

Pos.	Code	Description	Q.ty	Pos.	Code	Description	Q.ty
1	1401200700	OIL DRIPPER	2	59	4026102808	SCREW TE 8.8 M8X30 ZINC.	2
2	1521500500	ROTOR	1	60	4026102907	SCREW TE 8.8 M10X25 ZINC.	12
3	1587009400	SIDE OIL TANK	1	61	4026121305	SCREW TCEI 8.8 M6X16 ZINC.	2
4	1593600000	NON-RETURN VALVE	1	62	4026121401	SCREW TCEI 8.8 M8X12 ZINC.	2
5	1601601000	VANE	4	63	4026121710	SCREW TCEI 8.8 M12X35 ZINC.	2
6	1605500000	HANDLE	1	64	4026121808	SCREW TCEI 8.8 M10X25 ZINC.	2
7	1608100000	DISTRIBUTOR	1	65	4026121813	SCREW TCEI 8.8 M10X50 ZINC.	2
8	1608500000	CONVEYOR	1	66	4026135415	STUD SCREW 14.9 M8X50	1
9	1610512500	FRONT FLANGE	1	67	4026155505	SCREW TSPEI M5X16 ZINC.	4
10	16105CF2B0	OIL PUMP FLANGE	1	68	4026171211	GRUB SCREW 8.8 M12X80 ZINC.	2
11	16105E5BB0	FLANGIA POSTERIORE	1	69	4026300020	COMPENSATION RING	2
12	1622002600	SHAFT	1	70	4026305508	SELF-BLOCKING NUT M12	2
13	1623100000	MANIFOLD CAP	1	71	4026305614	SELF-BLOCKING NUT M24X2	1
14	162409YKBO	SPACER	1	72	4026308005	NUT M8 ZINC.	2
15	1624202300	SPACER	1	73	4026350508	WASHER GROWER 12 ZINC.	2
16	1627500000	MANIFOLD	1	74	4026351504	WASHER M6 ZINC.	4
17	1640003900	FRONT COVER	1	75	4026351505	WASHER M8 ZINC.	23
18	1642100200	REAR PROTECTION	1	76	4026351506	WASHER M10 ZINC.	12
19	1651009600	GEAR	1	78	4026401806	PIN 10X36	2
20	1651009700	GEAR	1	79	4026500018	TAB 6X10	1
21	1663018500	LUBRICATION PIPELINE	1	80	4026702000	FITTING 4X1/8	6
22	1663062900	LUBRICATION PIPELINE	1	81	4026706000	FITTING 4X1/8 (90°)	2
23	16630DJLBO	LUBRICATION PIPELINE	1	82	4026706003	FITTING 6X1/8 (90°)	1
24	16630DJMBO	LUBRICATION PIPELINE	1	83	4026706101	FITTING	2
25	16630DJNBO	LUBRICATION PIPELINE	1	84	4026904503	PLUG M20X1,5	1
26	16630DJPBO	LUBRICATION PIPELINE	1	85	4026905002	PLUG ¼ ZINC.	1
27	1673001000	OIL FILTER PLUG	1	86	4026910103	VENTIL PLUG 1"	1
28	1680600100	MANIFOLD GASKET	1	87	4026910601	PLUG 1/8	2
29	1680609700	OIL PUMP GASKET	1	88	4029602701	NUT M8 CAP	1
30	1680609800	OIL PUMP FLANGE GASKET	1	89	4029602806	DRIVE SHAFT PROTECTION	1
31	1680700200	MANIFOLD CAP GASKET	1				
32	1680708900	FRONT COVER GASKET	1	1892000000	GASKET KIT PN 106 M		1
33	1681007900	PLATE	1				
34	1681100100	OIL DRIPPER PLATE	2				
35	1684000000	DRAIN PLUG 3/8	3				
36	1685002800	WASHER FE 30X8,5 ZINC.	1				
37	1685100000	OIL DRIPPER WASHER 14X20X1,5	2				
38	1685100100	WASHER 10X16X1,5	4				
39	1685100200	WASHER 17X22X1,5	3				
40	1685100300	WASHER D20	2				
41	1685100800	WASHER 8X14X1,5	2				
42	1685600200	WASHER VULKOLAN 90SH 47,5X13X2	2				
43	1687500500	HOUSING	1				
44	1691000000	SPRING	1				
45	4022106001	OIL LEVEL	1				
46	4022200030	SEAL 41X27X10	1				
47	4022200040	SEAL 72X40X10	1				
48	4022200110	SEAL 72X48X15	2				
49	4022200240	O-RING 4825	2				
50	4022300001	NYLON FILTER	1				
51	4023100020	BEARING 6207	1				
52	4023100030	BEARING 6208	1				
53	4023100040	BEARING 6308	2				
54	4024251000	OIL PUMP	1				
55	4026102704	SCREW TE 8.8 M6X16 ZINC.	2				
56	4026102802	SCREW TE 8.8 M8X12 ZINC.	3				
57	4026102806	SCREW TE 8.8 M8X20 ZINC.	4				
58	4026102807	SCREW TE 8.8 M8X25 ZINC.	17				

**PN 45-58-84-106 ACCESSORIES**

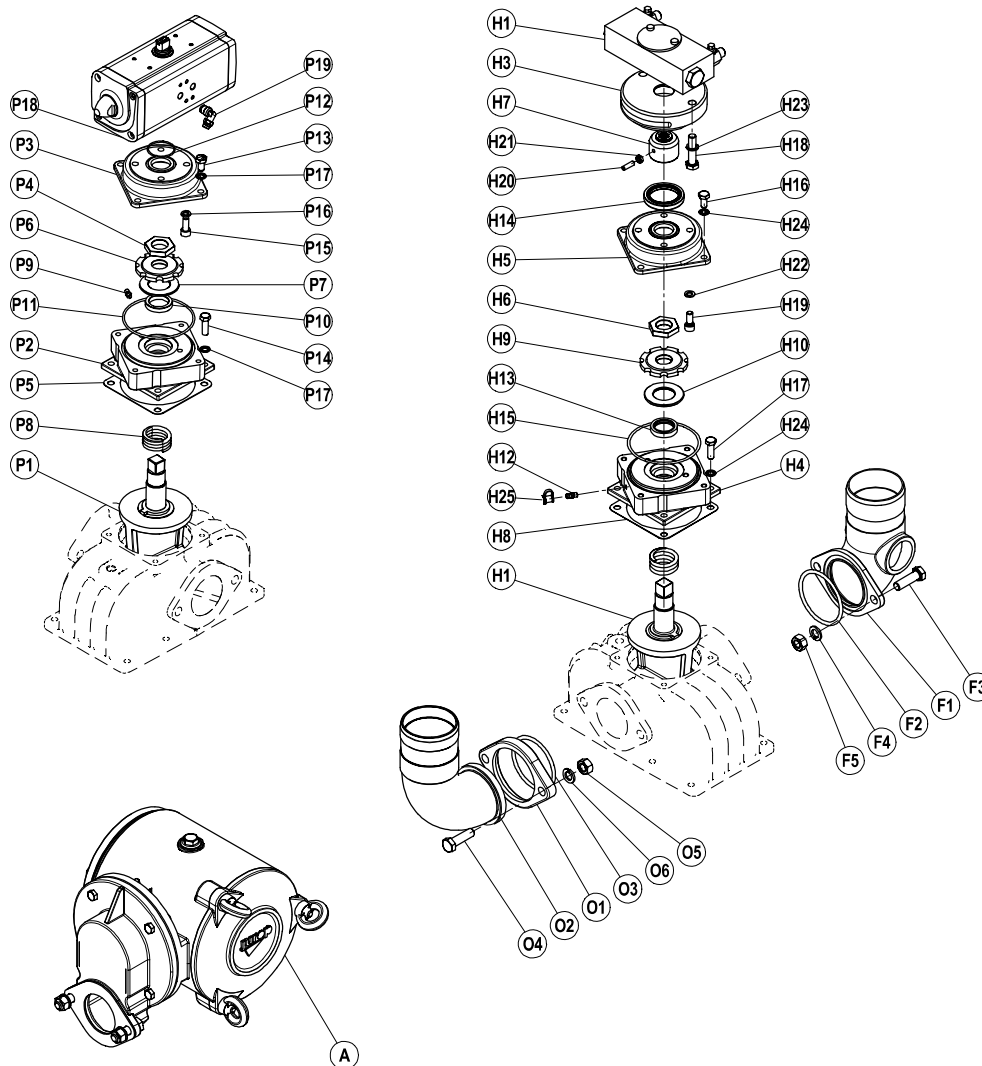

Pos.	Code	Description	Q.ty	Pos.	Code	Description	Q.ty
	<b>143027YZB0</b>	<b>PNEUMATIC OPERATED 4-WAY KIT</b>			<b>14302034E0</b>	<b>HYDRAULIC OPERATED 4-WAY KIT</b>	
P1	160857Z7B0	CONVEYOR	1	H1	14302031E0	HYDRAULIC ACTUATOR	1
P2	161258B4B0	SUPPORT FLANGE	1	H2	160857Z7B0	CONVEYOR	1
P3	1640580QB0	COVER	1	H3	16100416E0	HYDRAULIC ACTUATOR FLANGE	1
P4	167007ZAB0	NUT	1	H4	161258B4B0	SUPPORT FLANGE	1
P5	1680700200	GASKET	1	H5	1640580QB0	HYDRAULIC ACTUATOR COVER	1
P6	168409PQB0	WASHER	1	H6	167007ZAB0	NUT	1
P7	168529TFB0	SPACER	1	H7	16732001E0	COUPLER	1
P8	1691000200	SPRING	1	H8	1680700200	CONVEYOR-CAP GASKET	1
P9	4022100100	GREASER M6X1	1	H9	168409PQB0	RING NUT	1
P10	4022200005	SEAL 37X27X7	1	H10	168529TFB0	SPACER	1
P11	4022200330	O-RING 3375	1	H11	1691000200	SPRING	1
P12	4022200331	O-RING 2137	1	H12	4022100100	GREASER M6X1	1
P13	4026102804	SCREW TE 8.8 M8X16 ZINC.	4	H13	4022200005	SEAL 37X27X7	1
P14	4026102807	SCREW TE 8.8 M8X25 ZINC.	4	H14	4022200027	SEAL 55X40X8	1
P15	4026121405	SCREW TCEI 8.8 M8X20 ZINC.	4	H15	4022200330	O-RING 3375	1
P16	4026350505	WASHER GROWER 8 ZINC.	4	H16	4026102804	SCREW TE 8.8 M8X16 ZINC.	4
P17	4026351505	WASHER M8 ZINC.	8	H17	4026102807	SCREW TE 8.8 M8X25 ZINC.	4
P18	4027100477	PNEUMATIC ACTUATOR	1	H18	4026102911	SCREW TE 8.8 M10X45 ZINC.	2
P19	4027421206	FITTING	2	H19	4026121405	SCREW TCEI 8.8 M8X20 ZINC.	4

Pos.	Code	Description	Q.ty	Pos.	Code	Description	Q.ty
H20	4026136209	STUD SCREW 14.9 M6X20 ZINC.	1		<b>18521056E0</b>	<b>SUCTION CONVEYOR KIT Ø60</b>	
H21	4026301503	NUT M6 ZINC.	1	F1	1627100100	CONVEYOR Ø60	1
H22	4026312B01	WASHER D.8	4	F2	4022200250	O-RING 6287	1
H23	4026350708	WASHER GROWER 10 ZINC.	2	F3	4026103004	SCREW TE 8.8 M12X40 ZINC.	2
H24	4026351505	WASHER M8 ZINC.	8	F4	4026308007	NUT M12 ZINC.	2
H25	4029602700	CAP	1	F5	4026350709	WASHER GROWER 12 ZINC.	2
	<b>1852104800</b>	<b>DELIVERY CONVEYOR KIT Ø76</b>			<b>18521057E0</b>	<b>SUCTION CONVEYOR KIT Ø76</b>	
O1	1610100000	FLANGE	1	F1	1627100200	CONVEYOR Ø76	1
O2	1627100500	CONVEYOR Ø76	1	F2	4022200250	O-RING 6287	1
O3	4022200250	O-RING 6287	1	F3	4026103004	SCREW TE 8.8 M12X40 ZINC.	2
O4	4026103004	SCREW TE 8.8 M12X40 ZINC.	2	F4	4026308007	NUT M12 ZINC.	2
O5	4026308007	NUT M12 ZINC.	2	F5	4026350709	WASHER GROWER 12 ZINC.	2
O6	4026350709	WASHER GROWER 12 ZINC.	2		<b>1852104700</b>	<b>SUCTION CONVEYOR KIT Ø80</b>	
	<b>18521024E0</b>	<b>DELIVERY CONVEYOR KIT Ø80</b>		F1	1627100300	CONVEYOR Ø80	1
O1	16101003E0	FLANGE	1	F2	4022200250	O-RING 6287	1
O2	16271014E0	CONVEYOR Ø80	1	F3	4026103004	SCREW TE 8.8 M12X40 ZINC.	2
O3	4022200250	O-RING 6287	1	F4	4026308007	NUT M12 ZINC.	2
O4	4026103004	SCREW TE 8.8 M12X40 ZINC.	2	F5	4026350709	WASHER GROWER 12 ZINC.	2
O5	4026308007	NUT M12 ZINC.	2		<b>185219N7B0</b>	<b>FILTER</b>	
O6	4026350709	WASHER GROWER 12 ZINC.	2	A			

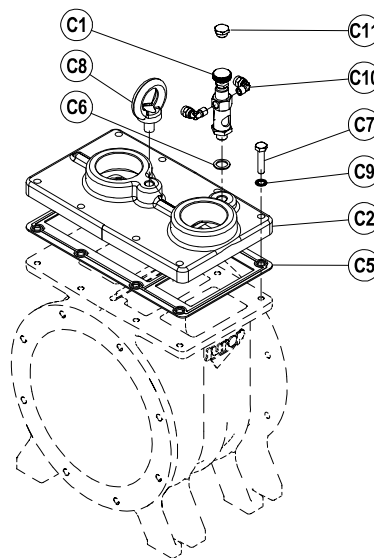
**PN with flange (FL)**

Pos.	Code	Description	Q.ty	Pos.	Code	Description	Q.ty
		<b>PN 45-58-84 WITH FLANGE</b>				<b>PN 106 WITH FLANGE</b>	
FL1	1401200400	MANUAL OIL DRIPPER	1	FL2	1610506400	FLANGE	1
FL2	1610506400	FLANGE	1	FL5	1680600100	MANIFOLD GASKET	1
FL3	1663022400	DELIVERY PIPE	1	FL7	4026102801	SCREW M8X35	8
FL4	1663022500	SUCTION PIPE	1	FL8	4026190001	EYE-BOLT M12	1
FL5	1680600100	MANIFOLD GASKET	1	FL9	4026351505	WASHER M8 ZINC.	8
FL6	1685100000	WASHER 14X20X1,5	1	FL11	4026905002	PLUG 1/4"	1
FL7	4026102801	SCREW M8X35	8				
FL8	4026190001	EYE-BOLT M12	1				
FL9	4026351505	WASHER M8 ZINC.	8				
FL10	4026706000	FITTING 4X1/8 90°	2				



**PN MIXER**

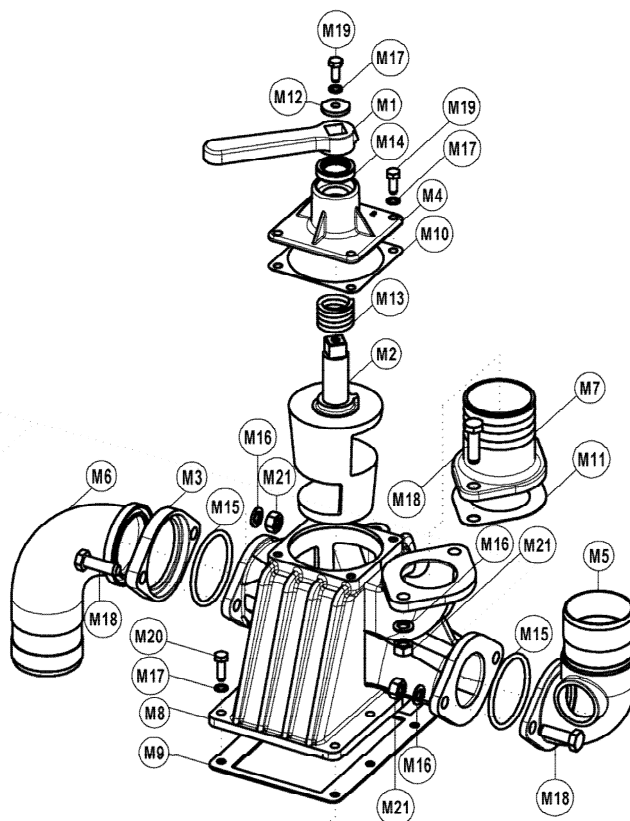

Pos.	Code	Description	Q.ty	Pos.	Code	Description	Q.tà
<b>PN 45-58-84 MIXER</b>				<b>PN 106 MIXER</b>			
M1	160550000	HANDLE	1	M1	160550000	HANDLE	1
M2	1608500100	MIXER MANIFOLD	1	M2	1608500100	MIXER MANIFOLD	1
M3	1610100000	CONVEYOR FLANGE	1	M3	1610100000	CONVEYOR FLANGE	1
M4	1623100000	MANIFOLD FLANGE	1	M4	1623100000	MANIFOLD FLANGE	1
M5	1627100200	SUCTION CONVEYOR Ø76	1	M5	1627100200	SUCTION CONVEYOR Ø76	1
M6	1627100500	EXHAUST MANIFOLD Ø76	1	M6	1627100500	EXHAUST CONVEYOR Ø76	1
M7	1627100700	SUCTION CONVEYOR Ø60 MIX	1	M7	1627100800	SUCTION CONVEYOR Ø76 MIX	1
	1627100900	SUCTION CONVEYOR Ø80 MIX	1	M8	1627500100	MANIFOLD	1
M8	1627500100	MANIFOLD	1	M9	1680600100	MANIFOLD GASKET	1
M9	1680600100	MANIFOLD GASKET	1	M10	1680700200	GASKET	1
M10	1680700200	GASKET	1	M11	1680700600	GASKET	1
M11	1680700600	GASKET	1	M12	1685002800	WASHER 30X8,5	1
M12	1685002800	WASHER 30X8,5	1	M13	1691000000	SPRING	1
M13	1691000000	SPRING	1	M14	4022200030	SEAL 41X27X10	1
M14	4022200030	SEAL 41X27X10	1	M15	4022200250	O-RING 6287	2
M15	4022200250	O-RING 6287	2	M16	4026350709	WASHER GROWER 12 ZINC.	6
M16	4026350709	WASHER GROWER 12 ZINC.	6	M17	4026351505	WASHER M8 ZINC.	13
M17	4026351505	WASHER M8 ZINC.	13	M18	4026103004	SCREW TE 8.8 M12X40 ZINC.	6
M18	4026103004	SCREW TE 8.8 M12X40 ZINC.	6	M19	4026102806	SCREW TE 8.8 M8X20 ZINC.	5
M19	4026102806	SCREW TE 8.8 M8X20 ZINC.	5	M20	4026102807	SCREW TE 8.8 M8X25 ZINC.	8
M20	4026102807	SCREW TE 8.8 M8X25 ZINC.	8	M21	4026308007	NUT M12	6
M21	4026308007	NUT M12	6				

<b>Model</b>	<b>Issue date</b>	<b>Revision No.</b>	<b>Revision date</b>	<b>Filled out by</b>	<b>Viewed by</b>
PN	01-01-2002	10	22-04-2020	U.T.	A.T.

## **Juop SpA**

Via Crosera, 50  
33082 Azzano Decimo, PN (ITALY)

Tel. +39 0434 636811  
Fax. +39 0434 636812

<http://www.juop.it>  
e-mail: [info@juop.it](mailto:info@juop.it)

J Juop SpA reserves the right to modify the products described in this manual without prior notice.