

	EQUIPAGGIAMENTI TECNICI LAVAGGIO	25.0700.12 HL 250	Ⓛ Ⓜ	4
			23/09/05	

UGELLO AD ANGOLO VARIABILE + BYPASS
VARIABLE ANGLE NOZZLE + BYPASS

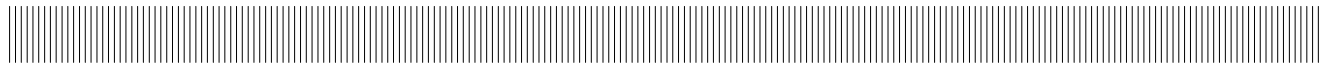

CARATTERISTICHE TECNICHE
SPECIFICATIONS

- PRESSIONE NOMINALE RATED PRESSURE	250 bar – 25 MPa (3650 psi)
- PRESSIONE CONSENTITA PERMISSIBLE PRESSURE	280 bar – 28 MPa (4050 psi)
- PORTATA MASSIMA MAX FLOW RATE	40 l/min (10.5 USG p.m.)
- TEMPERATURA MASSIMA MAX WORKING TEMPERATURE	90° C (195°F)
- UGELLO M4 (FATTORE DI PORTATA) NOZZLE M4 (CAPACITY SIZE)	02-025-03-032-035-037-04-043- -045-05-053-056-06-065-07-08

MISURE D'INGOMBRO
OVERALL DIMENSIONS

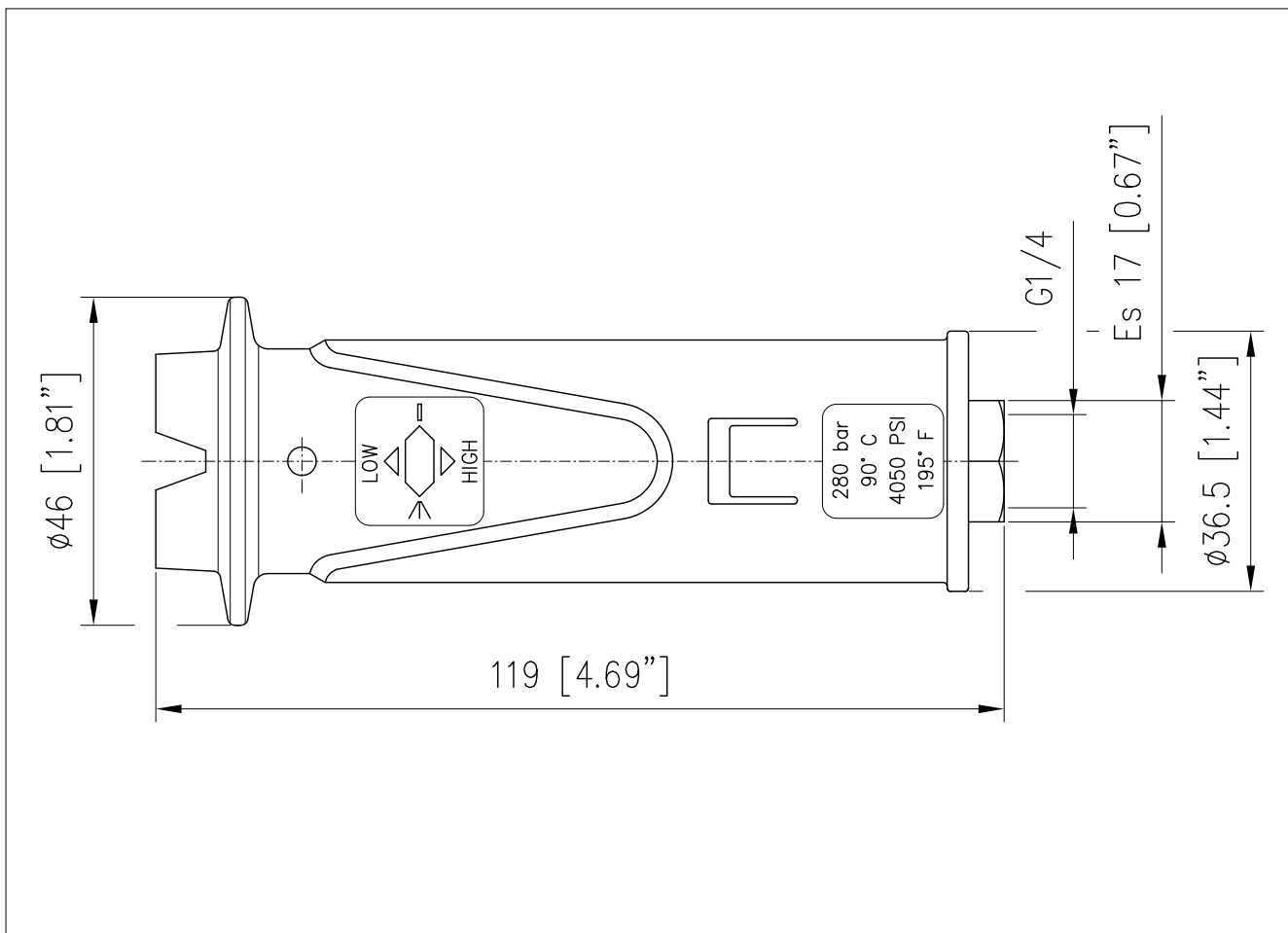

25.0700.10 HL250-02 Ug.ang.var.+byp.G1/4F
 25.0700.11 HL250-025 Ug.ang.var.+byp.G1/4F
 25.0700.12 HL250-03 Ug.ang.var.+byp.G1/4F
 25.0700.13 HL250-035 Ug.ang.var.+byp.G1/4F
 25.0700.14 HL250-04 Ug.ang.var.+byp.G1/4F

25.0700.15 HL250-045 Ug.ang.var.+byp.G1/4F
 25.0700.16 HL250-053 Ug.ang.var.+byp.G1/4F
 25.0700.25 HL250-032 Ug.ang.var.+byp.G1/4F
 25.0700.35 HL250-037 Ug.ang.var.+byp.G1/4F

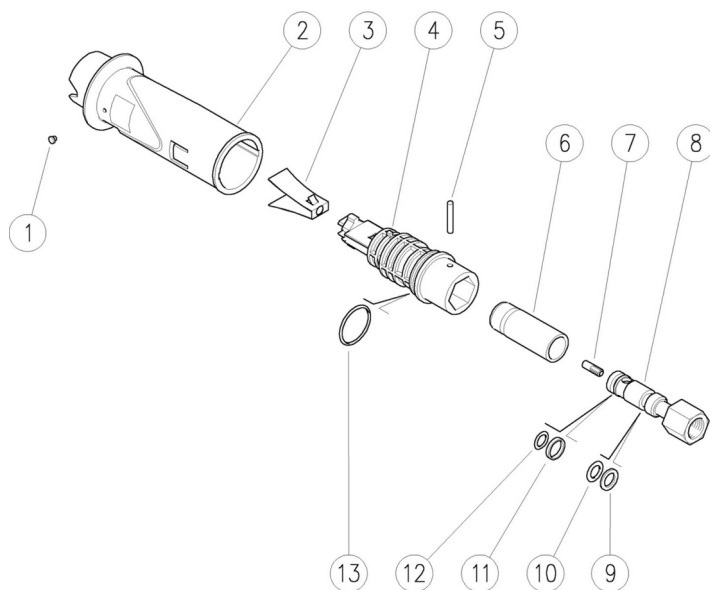

Pos.	Codice	Descrizione	Q.tà	K1	K2	K3	K4	
1	15.2000.20	Chiodo 02 verde chiaro (1)	1					10
2	25.0705.84	Manopola ugello nera	1					5
3	25.1303.51	Deflettore inox	1	•				10
4	25.0702.84	Corpo deflettore POM	1					10
5	15.1037.00	Spina cil. 3x23 mm inox	1					10
6	25.0703.31	Astuccio	1					5
7	25.1190.51	Ugello 02 - M4 inox verde chiaro (1)	1					10
7	25.1091.51	Ugello 025 - M4 inox rosa (2)	1					10
7	25.1092.51	Ugello 03 - M4 inox bianco (3)	1					10
7	25.1093.51	Ugello 035 - M4 inox marrone (4)	1					10
7	25.1094.51	Ugello 04 - M4 inox giallo scuro (5)	1					10

Pos.	Codice	Descrizione	Q.tà	K1	K2	K3	K4	
7	25.1095.51	Ugello 045 - M4 inox blu (6)	1					10
7	25.1196.51	Ugello 053 - M4 inox beige (7)	1					10
7	25.1193.51	Ugello 032 - M4 inox viola scuro (8)	1					10
7	25.1098.51	Ugello 037 - M4 inox rosso chiaro (9)	1					10
8	25.0701.31	Perno G1/4 F ott.	1					5
9	10.4032.00	An. anties. 8x12x1,2 mm	1	•				10
10	10.3109.92	An.OR 2,4x7,3 mm	1	•				10
11	10.4150.00	Guarn. stelo 10,2x12,2x2mm	1	•				10
12	10.3052.00	An.OR 1,78x6,75 mm	1	•				25
13	10.3072.50	An.OR 1,78x21,95 mm	1	•				10

Kit	Codice	Descrizione	
K1	25.0708.24	Kit ric. HL250 6x1pz.	1

(1) 25.0700.10 (2) 25.0700.11 (3) 25.0700.12 (4) 25.0700.13 (5) 25.0700.14 (6) 25.0700.15 (7) 25.0700.16 (8) 25.0700.25 (9) 25.0700.35

25.0700.10 HL250-02 var.angle nzl+Hi/Lo set. Bsp
 25.0700.11 HL250-025 var.angle nzl+Hi/Lo set. Bsp
 25.0700.12 HL250-03 var.angle nzl+Hi/Lo set. Bsp
 25.0700.13 HL250-035 var.angle nzl+Hi/Lo set. Bsp
 25.0700.14 HL250-04 var.angle nzl+Hi/Lo set. Bsp

25.0700.15 HL250-045 var.angle nzl+Hi/Lo set. Bsp
 25.0700.16 HL250-053 var.angle nzl+Hi/Lo set. Bsp
 25.0700.25 HL250-032 var.angle nzl+Hi/Lo set. Bsp
 25.0700.35 HL250-037 var.angle nzl+Hi/Lo set. Bsp

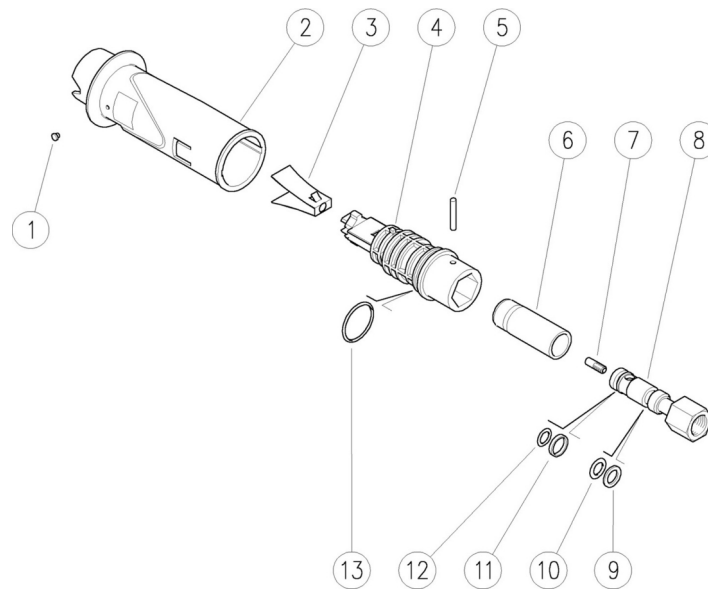

Pos.	P/N	Description	Q.ty	K1	K2	K3	K4	
1	15.2000.20	Stud, 02 light green (1)	1					10
2	25.0705.84	Nozzle knob, black	1					5
3	25.1303.51	Sst deflector	1	•				10
4	25.0702.84	Deflector housing, POM	1					10
5	15.1037.00	Parallel pin, 3x23 mm Sst.	1					10
6	25.0703.31	Case	1					5
7	25.1190.51	Nozzle, 02 - M4 Sst. light green (1)	1					10
7	25.1091.51	Nozzle, 025 - M4 Sst. pink (2)	1					10
7	25.1092.51	Nozzle, 03 - M4 Sst. white (3)	1					10
7	25.1093.51	Nozzle, 035 - M4 Sst. brown (4)	1					10
7	25.1094.51	Nozzle, 04 - M4 Sst. dark yellow (5)	1					10

Pos.	P/N	Description	Q.ty	K1	K2	K3	K4	
7	25.1095.51	Nozzle, 045 - M4 Sst. blue (6)	1					10
7	25.1196.51	Nozzle, 053 - M4 Sst. beige (7)	1					10
7	25.1193.51	Nozzle, 032 - M4 Sst. dark purple (8)	1					10
7	25.1098.51	Nozzle, 037 - M4 Sst. -light red (9)	1					10
8	25.0701.31	Pin, 1/4F Bsp brass	1					5
9	10.4032.00	Back-up ring, 8x12x1,2 mm	1	•				10
10	10.3109.92	O-ring, 2,4x7,3 mm	1	•				10
11	10.4150.00	Stem seal, 10,2x12,2x2 mm	1	•				10
12	10.3052.00	O-ring, 1,78x6,75 mm	1	•				25
13	10.3072.50	O-ring, 1,78x21,95 mm	1	•				10

Kit	P/N	Description	
K1	25.0708.24	Spares kit HL250 6x1pcs.	1

(1) 25.0700.10 (2) 25.0700.11 (3) 25.0700.12 (4) 25.0700.13 (5) 25.0700.14 (6) 25.0700.15 (7) 25.0700.16 (8) 25.0700.25 (9) 25.0700.35



P.A. S.p.A.
Via Milano, 13
42048 Rubiera, Reggio Emilia - Italy
Tel +39.0522.623611
Fax +39.0522.629600
info@pa-etl.it

www.pa-etl.it



COMPANY WITH QUALITY MANAGEMENT
SYSTEM CERTIFIED BY DNV
= ISO 9001 =