



METALTECNICA s.r.l.

Via G. Matteotti, 151 – 28077 Prato Sesia (No) – Italy Tel. +39 0163 850497 – Fax +39 0163 851212

e-mail: mz@metaltecnicazanolo.com

http: www.metaltecnicazanolo.com

INSTALLATION – USE – MAINTENANCE MANUAL

ARTT. 0020 – 0020/L – 0021 THREE WAYS FLANGED COCK

ART. 0020/600 THREE WAYS FLANGED COCK WITH HYDRAULIC CYLINDER

ART. 0020/620 THREE WAYS FLANGED COCK WITH PNEUMATIC ACTUATOR



ISTR 0020_EN

EDITION 1/2015

INDEX

1. Description
 - 1.1 Product typologies
 - 1.2 Symbols agreement
 - 1.3 Marking and certifications
2. Handling
3. Installation
4. Operations
5. Dimensions - materials - work conditions
6. Use limits
7. Maintenance
 - 7.1 Ordinary maintenance
 - 7.2 Extraordinary maintenance
8. Storage
9. Disposal

1. Description

Conical male flanged three ways cock (cylindrical per DN 10") workable manually with lever or with oildynamic and pneumatic actuators, usable in plants for interception and deviation of liquid manure, biomasses with short fibre, dense and muddy liquids.

1.1 Product typologies

ART. 0020

Flanged three ways cock, **T** male, in manual version without control lever.
DN available: 3"- 4"- 5"- 6"- 8"-10".

ART. 0020/L

Flanged three ways cock, **T** male, in manual version without control lever.
DN available: 3"- 4"- 5"- 6".

ART. 0020/600

Flanged three ways cock, **T** male, completed of double effect oildynamic cylinder art. 0600.
DN available: 4"- 5"- 6"- 8".

ART. 0020/620

Flanged three ways cock, **T** male, completed of double effect pneumatic actuator art. 0620.
DN available: 3"- 4"- 5"- 6"- 8"-10".

ART. 0021

Flanged three ways cock, **L** male, in manual version without control lever.
DN available: 4".

ART. 0021/L

Flanged three ways cock, **L** male, in manual version without control lever.
DN available: 4".

ART. 0021/600

Flanged three ways cock, **L** male, completed of double effect oildynamic cylinder art. 0600.
DN available: 4".

ART. 0021/620

Flanged three ways cock, **L** male, completed of double effect pneumatic actuator art. 0620.
DN available: 4".

1.2 Symbols agreement



This symbol highlights information and/or instructions that are fundamental for the lesions prevention also serious to the user and/or damages to the product, to the plant and to the ambient.

1.3 Marking and certifications

1.3.1 PED directive (97/23/CE)

The cocks are considered containers in pressure and are so subjected to the PED directive (97/23/CE). The PED directive compares the valves to the pipes. The applicable conformance evaluation table is the table 9, "pipes of the art.3, comma 1, letter c, point 2, second dash. It is referred to "pipes destined to liquids with a vapor tension to the acceptable maximum temperature inferior or equal to 0,5 bar over the normal atmospheric pressure (1.013 mbar), within the following limits:

Group 2 fluids, when PS is superior to 10 bar, DN is superior to 200 and the product PS x DN is superior to 5.000 bar.

In the specific the cocks are part in the application zone of the article 3, comma 3 and must not be CE marked.

1.3.2 Machines Directives (2006/42/CE)

The cock equipped with oildynamic or pneumatic actuators are considered machines and are subjected to the directive 2006/42/CE. The cocks satisfy the safety minimum requirements requested by the directive.

2. Handling

During the handling it is necessary to respect the following indications:

- Use adequate personal protection accessories (gloves, protection glasses, anti-accidental shoes, etc).
- ⚠ The cocks with weight superior to 20 Kg must be livened with cranes, tackle or elevator trolley with the help of adequate slings.
- Avoid to liven the cock supporting it by the oildynamic or pneumatic actuators.
- During the handling pay attention that the cock doesn't suffer impacts and damages.
- ⚠ The protective painting damage can provoke the quick arise of corrosive phenomenon.

3. Installation

During the installation it is necessary to respect the following indications:

- Liven the cock respecting the warnings showed to the points 2 "Livening"
- Check the cock verifying the perfect integrity and the internal parts cleaning.
- Verify the cock correct positioning respect to the desired flow direction. On the control lever (available up to DN 6") there are 4 arrows that give immediate indications of the three ways opened or closed condition. The manoeuvre lever (and so the arrow with the letter "C") must correspond always to the male closed side. In manual version it is possible to perform the rotation of 360° of the internal male while with the oildynamic or pneumatic actuators it is possible to perform only a manoeuvre rotation of 90° and the next return to the departure position (see following diagrams).

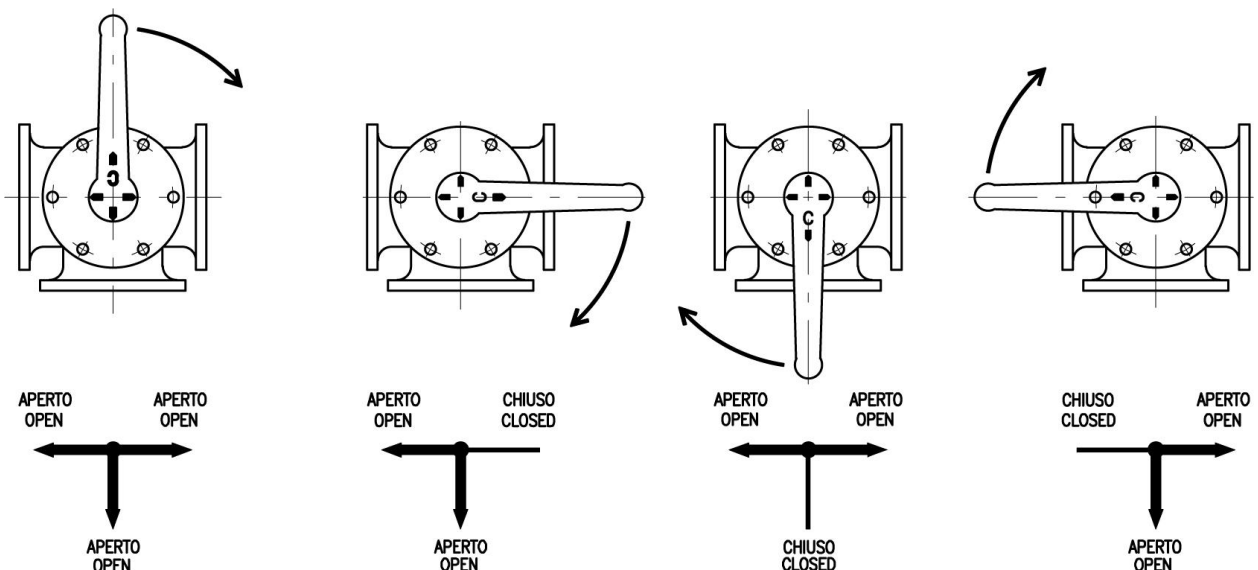

- Evaluate the installation position considering that when possible it is preferable to install the cock in vertical position on pipes with horizontal axle. The cock can be however installed in any other position.

Tab.1 examples of admitted installation positions

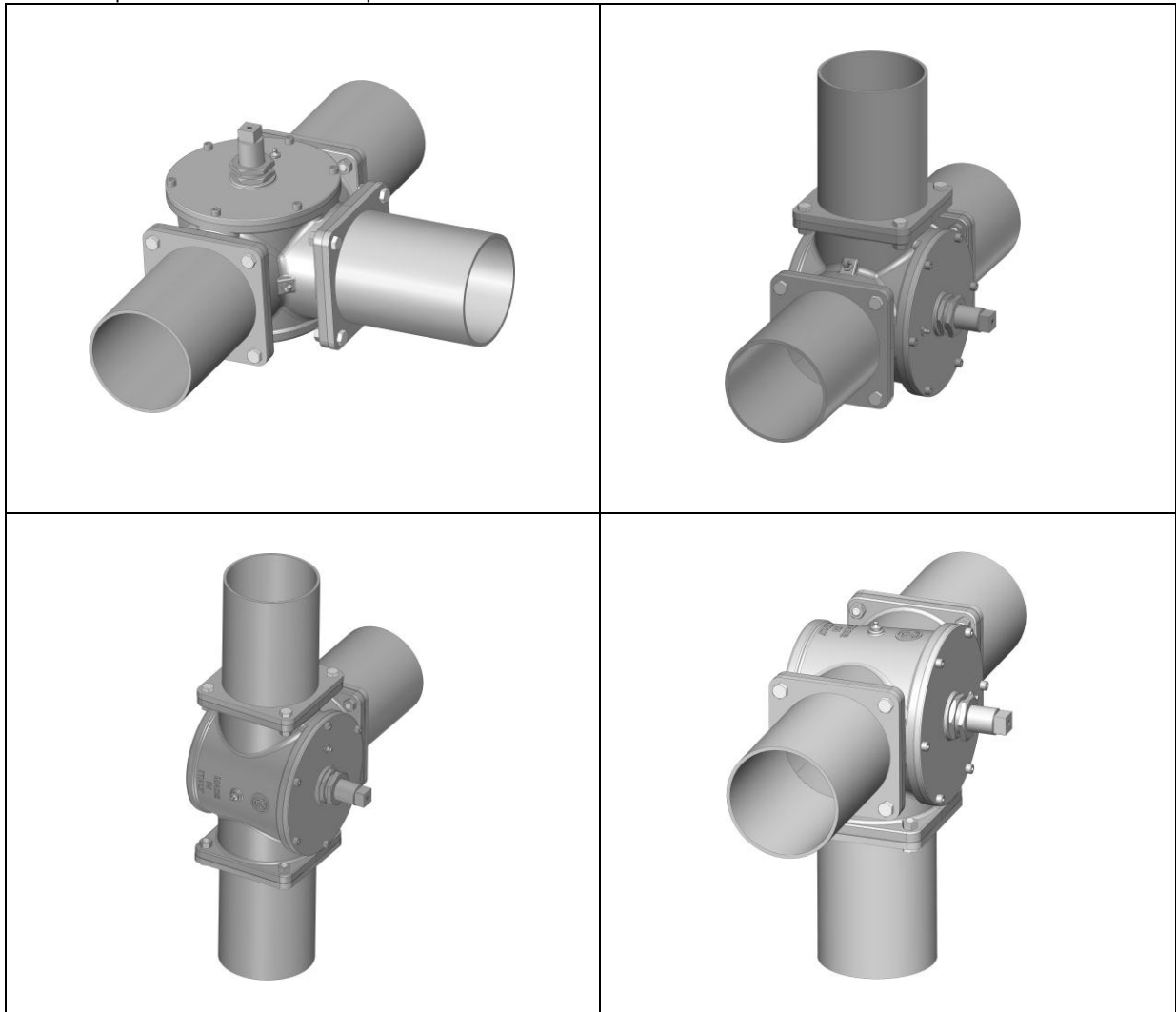

- Verify that the space between the connection flanges of three pipes section is correct and that the flanges are parallel/orthogonal and aligned. Errors of parallelism, orthogonally and alignment can provoke, in assembly phase, heavy stresses to the cock that could give structure collapses.
- In installation phase the cocks must be equipped with adequate support. At least two pipes sections must have the necessary supports to avoid that the plant stresses concentrate on the cock.
- Place the fastening screws and screw them alternatively and gradually; tighten a screw and then the screw diametrically opposite proceeding in the same way for all next screws. The correct tightening couple is showed in the following table.

Tab.2 suggested tightening couple

DN	3"	4"	5"	6"	8"	10"
Screws for flange	n.4 - M10	n.4 - M12	n.4 - M12	n. 4 - M12	n. 4 - M12	n. 6 - M12
Tightening couple (Nm)	60	70	70	70	70	70

- With the installed cock, control the accessories correct connection as oildynamic or pneumatic actuators. The information regarding the actuators installation, use and maintenance are showed further on in this manual.

⚠ **The use of actuators different from those standard supplied by Metaltecnica can provoke malfunctioning and/or damaging to the cock structure besides Metaltecnica guarantee decaying.**

- Perform some vacuum opening and closure cycles and then proceed to the cock put in service verifying the correct functioning.
- ⚠ Before disassembling the cock from the plant, for maintenance and/or change, interrupt the electric, pneumatic and oil dynamic feeding discharging the lines and the cock pressure.
- ⚠ Protect adequately the closure male surface during possible cock re-painting operations.

4. Operations

The cock can be supplied with two different operations types:

4.1 oildynamic actuator with double effect (art. 0600)

The cocks can be supplied with oil dynamic actuator with double effect completed of plate-cock and control lever. For what regard the technical details and the oildynamic cylinder use conditions you refer to the relative technical card. The information regarding the installation, use and maintenance are showed here follow.

Cock assembly procedure – oildynamic cylinder with double effect art. 0600

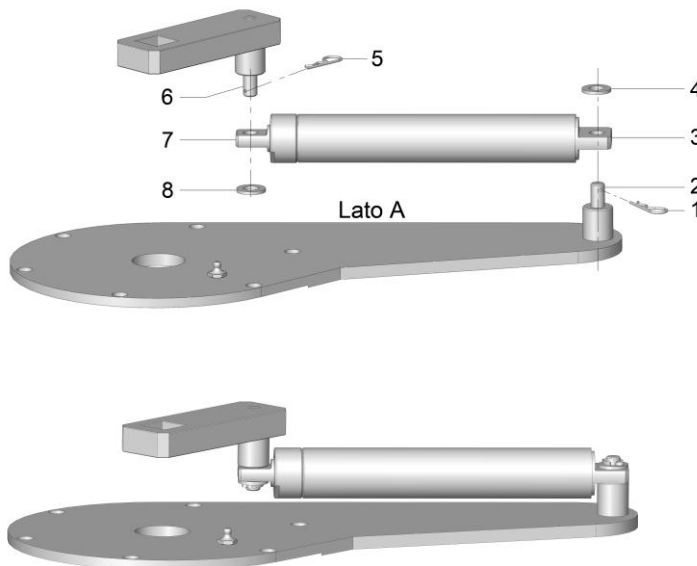

Oildynamic cylinder assembly on the plate

- Insert the plate pivot (2) in the cylinder terminal part (3), checking that the nipples joints are turned towards the side "A" of the plate.
- Place the washer (4) on the pivot
- Insert the split pin (1) for the fastening.
- Insert the lever pivot (6) in the pole terminal side (7).
- Place the washer (8) on the pivot
- Insert the split pin (5) for the fastening

Plate assembly with oildynamic cylinder to the cock

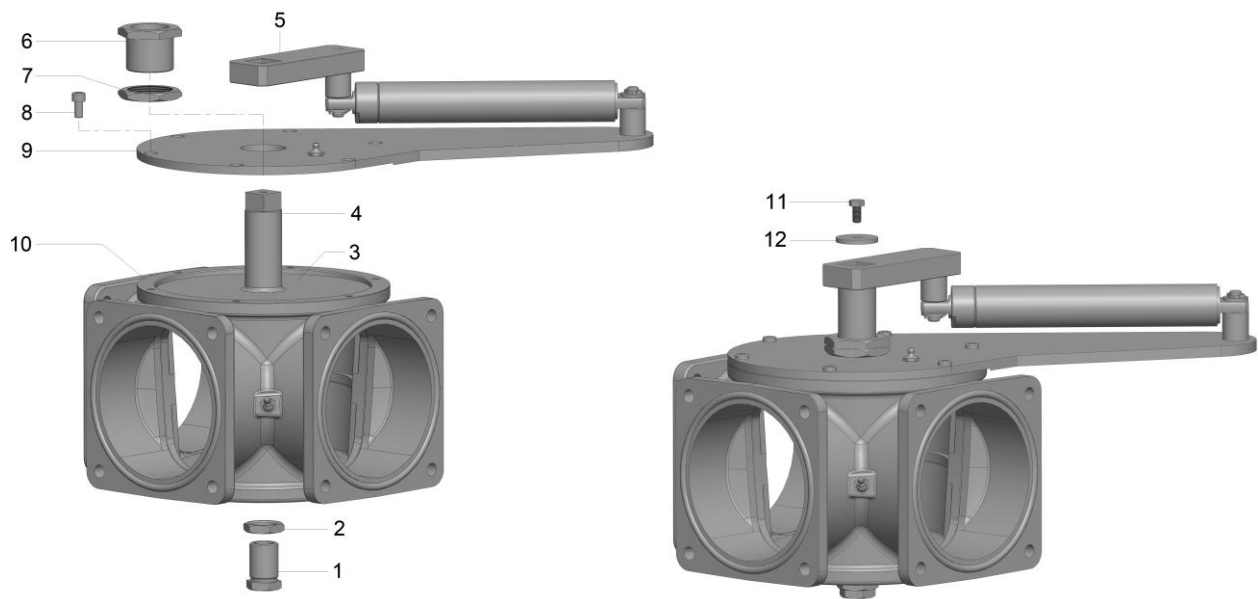

- Screw the metal ring (7) on the stuffer (6) up to put on frame.
- Screw partially the stuffer (6) on the plate (9): it is sufficient a screwing of 4÷5 mm (corresponding to about 2 threads).
- Consider that the actuator performs a rotation of 90° in anticlockwise (and relative return) respect to the all closed cylinder initial position (pole reentered). Verify so that this rotation opens and closes the cock in accordance with the plant needs.
- Place the plate (9) on the cock superior flange (10), inserting the manoeuvre panel (4) in the lever (5).
- Screw the fastening screws (8).
- Block the lever (5) to the manoeuvre panel, placing the washer (12) on the lever and screwing the screw (11) to the manoeuvre panel.
- Screw completely the stuffer (6) up to put in light frame on the male (3).
- Connect the hydraulic plant to the cylinder and perform 2-3 opening and closure cycles.
- Screw further the stuffer (6) up to put in light frame on the male and screw the thrust (1) up to put in light frame on the male (3).
- Unscrew the metal ring (7) up to put on frame on the plate (9) (lock nut action) and screw the metal ring (2) to put on frame on the cover (lock nut action) to block the obtained regulation.
- In use phase it could be necessary a further male position regulation with a stuffer screwing/unscrewing (6) and thrust metal ring (1), with the aim to obtain the best relation between tight level and manoeuvre effort.

Install the cock following the indications showed in the point **3. Installation** of the present manual.

4.2 Double effect pneumatic actuator (art. 0620)

The cocks can be supplied with double effect rotating pneumatic actuator. For what regard the technical details and the pneumatic actuator use conditions refer to the relative technical card. The information regarding the installation, use and maintenance are showed here follow.

Cock assembly – double effect pneumatic actuator procedure art. 0620

- Consider that the actuator performs a rotation of 90° in anticlockwise (and relative return) respect to the initial position. Verify so that this rotation opens and closes the cock in accordance with the specific plant needs.
- Verify that the opening profile presented on the male corresponds perfectly to the opening one presented on the body.
- Fasten the actuator to the fastening plate using 4 cylindrical head screws (6) and the relative 4 washers (5) supplied on equipment.

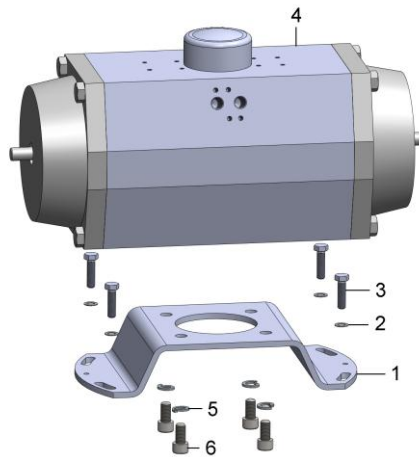

- Remove 4 cover fastening screws showed in figure with 1,2,3,4

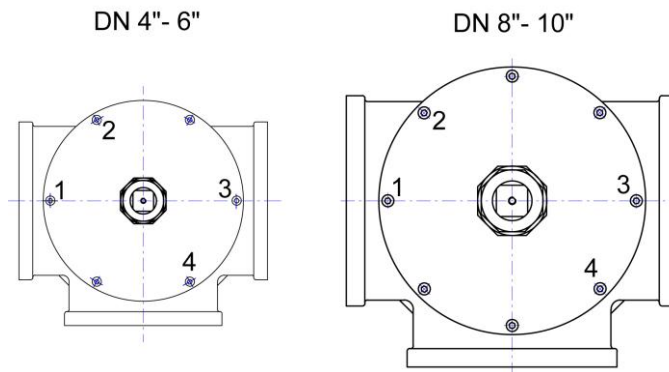

- Place the actuator on the cock engaging the manoeuvre panel in the corresponding square seat presented in the actuator inferior side.
- Fasten the plate to the cover using 4 hexagonal head screws and relative washers on equipment. The holes on the plate are looped to allow to compensate possible little geometric flaws.

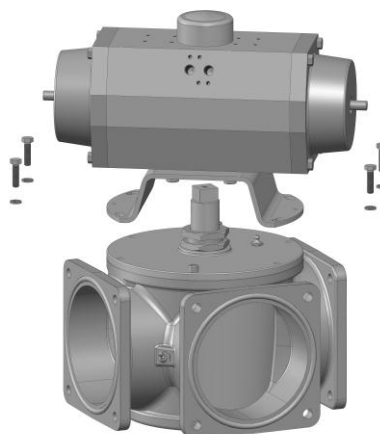

- ⚠ In assembly phase don't try to regulate the male position rotating the actuator; its internal parts could suffer damages.
- Connect the pneumatic line, **avoiding to use conic threading joint**, and perform some opening and closing cycles before putting in function the cock.
- If necessary it is possible to adjust the rotation of $\pm 3^\circ$ with the screws placed on the heads.

-  To avoid damages to the actuators internal pistons, we suggest to assemble some speed adaptors on the air inlets. In the application where the namur electric valve is assembled directly on the actuators some discharging regulators must be assembled on the electric valves discharges.

For further information regarding the accessories available for the pneumatic actuators (electric valves, box micro, etc.) contact Metaltecnica technical service.

5. Dimensions – materials – work conditions

The technical information regarding the size dimensions, the used materials and the exercise conditions are consultable on the company catalogue or on internet web site www.metaltecnicazanolo.com. The technical cards specific for every article can be requested to Metaltecnica technical department.

6. Use limits

- The cocks cannot be used in pressure conditions and temperatures different from those showed on the specific technical cards.
- The oildynamic and pneumatic actuators cannot be used in pressure conditions and temperatures different from those showed on the specific technical cards.
- The cocks cannot be used with fluids of the group 1 (DIR 97/23/CE) nor with fluids whose chemical composition isn't compatible with the materials constituting the cock.
- The not authorized modification, the improper use or the use limits inobservance of cocks and/or actuators, can behave serious damages both to the user and to the ambient and provokes the Metaltecnica guarantee decaying.

7. Maintenance

7.1 Ordinary maintenance

 The ordinary maintenance operations must be performed by qualified personnel and equipped with necessary personal protection means.

- Verify periodically the liquids leaks absence from the cock lid and the oil leaks absence from the oildynamic actuators.
- Foresee in the plant programmed maintenance cards some opening and closure cycles with predefined intervals for the cocks "normally closed" and for the cocks with manual opening lever, in particular in the cases where dense and fur liquids are treated, with the aim to avoid male blocking phenomenon.
- To guarantee a perfect and constant functioning of the cock it is necessary to provide periodically to the internal parts cleaning and to the male greasing, in particular when you foresee the cock unused prolonged periods. **The frequency of this maintenance is changeable in function of the cock work conditions.** For a correct greasing it is necessary to proceed as here follow showed:
 - Verify that the cock internal is sufficiently cleaned, remove possible furs that could prevent the male rotation and rotate the male so that all three ways are opened.
 - Proceed to a first greasing, preferably with manual pump greaser, through the greaser placed in the cock back part having care to introduce a small quantity of lithium fat NLGI 1.
 - Perform a second greasing with two greasers place to the central flange sides always introducing small quantities.
 - Perform some opening and closure manoeuvres, perform a second introduction of grease and again repeat the opening and closure manoeuvres.
 - Repeat, if necessary, the procedure.
 - Successively grease the male superior part with the greaser placed on the cover. In this case it is sufficient to get cock of grease, making only a modest pressure, the space presented between male level and the cover. The cock inferior part must be filled in the same way.

 The above mentioned procedure is valid for periodical greasing operations on cocks correctly functioning. If the cock is blocked and it isn't possible to perform opening and closure operations it is preferable to not perform greasing operations (they could even worsen the situation!) but rather to proceed to the cock disassembly, to the internal sides cleaning, to a careful greasing of the disassembled male and to the next putting in function of the cock.

⚠ The introduction of excessive quantity of grease can provoke also permanent deformations and even cock structure breaks.

7.2 Extraordinary maintenance

⚠ The extraordinary maintenance operations must be performed by qualified personnel and equipped with necessary personal protection means.

7.2.1 Male extraction and regulation “blocked” in the body (excluded DN 10”):

The more frequent cause of the male blockage inside the body is the internal parts fur. The error that often is made by the user after having unblocked the male (working on stuffer and thrust screw), is to not perform again the male regulation.

In fact if the male isn't again regulated after the unblocking, the space between the body and male increases sensitively (dealing of conic coupling) and in this space both the liquid manures and the extraneous bodies can easily slip (sand, stones, etc). Of consequence during the next rotations the extraneous bodies will provoke scratches and damages to the body and male surfaces and the liquid manure, drying, will provoke further furs and manoeuvre difficulties.

Here follow the procedure to perform the male unblocking from the cock body and the procedure for the next regulation of the male are showed.

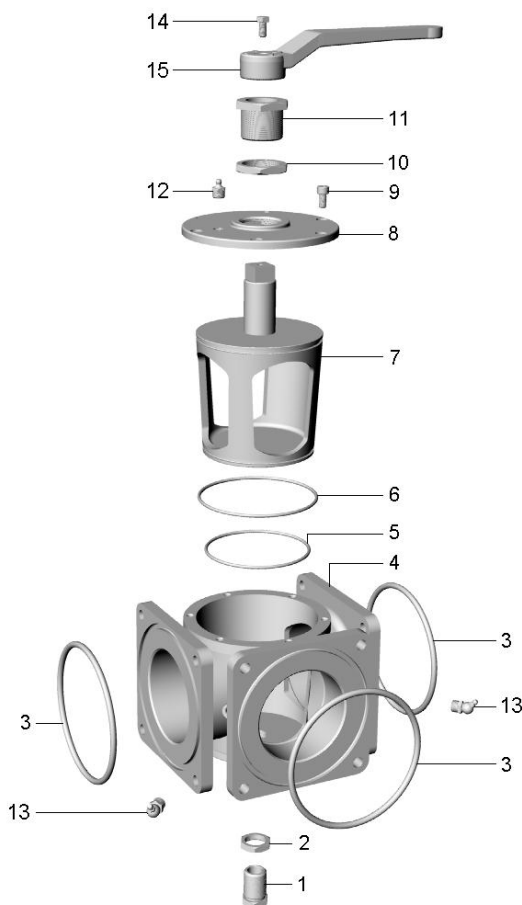

1. Slacken the metal ring (10) and screw for 4-5 mm the stuffer (11)
2. Unscrew the metal ring (2) for 4-5 mm
3. Screw of $\frac{1}{2}$ turn the thrust (1) and perform a first attempt of male rotation (7) with the handle (15) (manual version) or activating the hydraulic cylinder.
4. Screw further the thrust if the male is still blocked and perform a second rotation attempt.
5. Slacken the blockage screws (9) of the cover (8) or of the plate with cylinder
6. Slacken the screw (14) and take off the handle (15) or the plate lever with cylinder
7. Extract the male (7) from the cock body and proceed to the all parts cleaning changing if necessary the tight o-rings (5) and (6)
8. Replace the o-rings on the male and apply a thin grease layer on all male conic surface.
9. Insert the male (7) in the cock body (4)
10. Place the cover (or the plate with cylinder) fastening to the body with the screws (9)
11. Replace and fasten the handle (or the plate lever with cylinder) to the male.
12. Unscrew for 4-5 mm the thrust (1)
13. Screw the stuffer (11) up to put on contact with the male
14. Perform a complete male rotation (manual version) or one/two opening-closure cycle/s (version with cylinder)
15. Screw again the stuffer (11) up to put on contact with the male
16. Repeat the operation up to obtain the right compromise between tight level and manoeuvre effort.
17. With the regulation finished screw the thrust (1) up to put in support to the male and block it in position screwing the metal ring (2).
18. Screw successively the metal ring (10) to block the stuffer position (11).
19. Grease the cock as described at the point 7.1

Note: the above described procedure is referred to the intervention to perform in the case of cocks blocked due to blocks and furs, in the case where the cock is used with cleaned and not fur liquids it is possible to avoid the operations from 5 to 11 changing them with a cock greasing with the back greaser.

7.2.3 Oildynamic cylinder gaskets kit change

Here follow the procedure to perform the oildynamic cylinder gaskets kit change is showed.

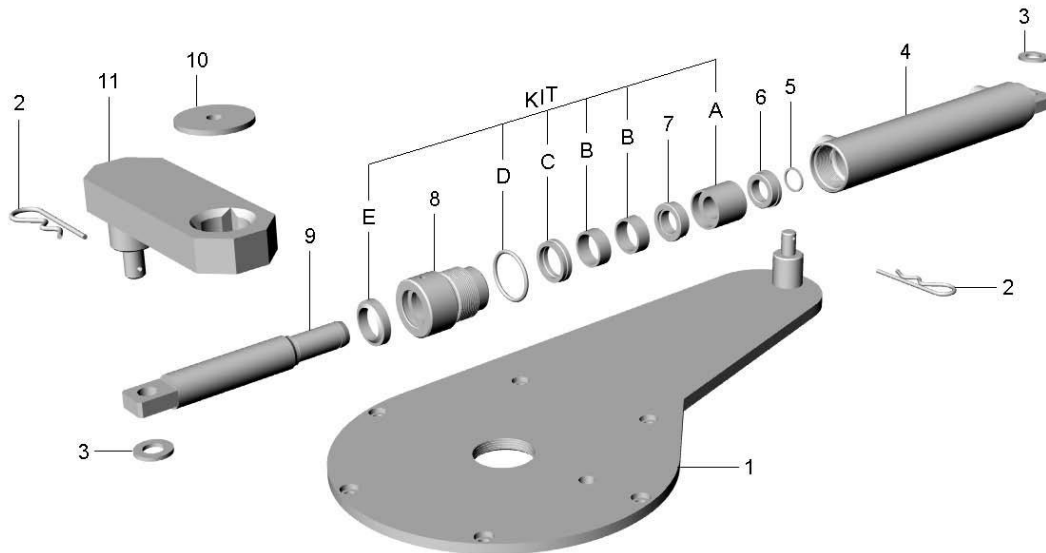

1. Discharge the oildynamic plant pressure and disconnect the cylinder from the plant.
2. Remove the lever fastening screw to the male stalk.
3. Remove the split pins (2) and the washers (3), take off the lever (11) from the cylinder pole (9) and from the male stalk.
4. Take off the cylinder from the plate (1).
5. Make flow the oil through two connection nipples
6. Block the cylinder in vise tightening on the terminal plate side opposed to the pole.
7. Unscrew completely the head (8) using a sector key and extract the pole (9) completed of all internal components.
8. Remove the stop ring (5) placed to the pole extremity (9) and take off the metallic rings (6 and 6) and the gaskets A – B – C - D .
9. Remove the gasket E from the head (8)
10. Clean all parts, change the gaskets and reassembly the cylinder following the opposite order to the disassembly one.

7.2.4 Pneumatic actuator gaskets kit change.

Here follow the procedure to perform the pneumatic actuator gaskets kit change is showed.

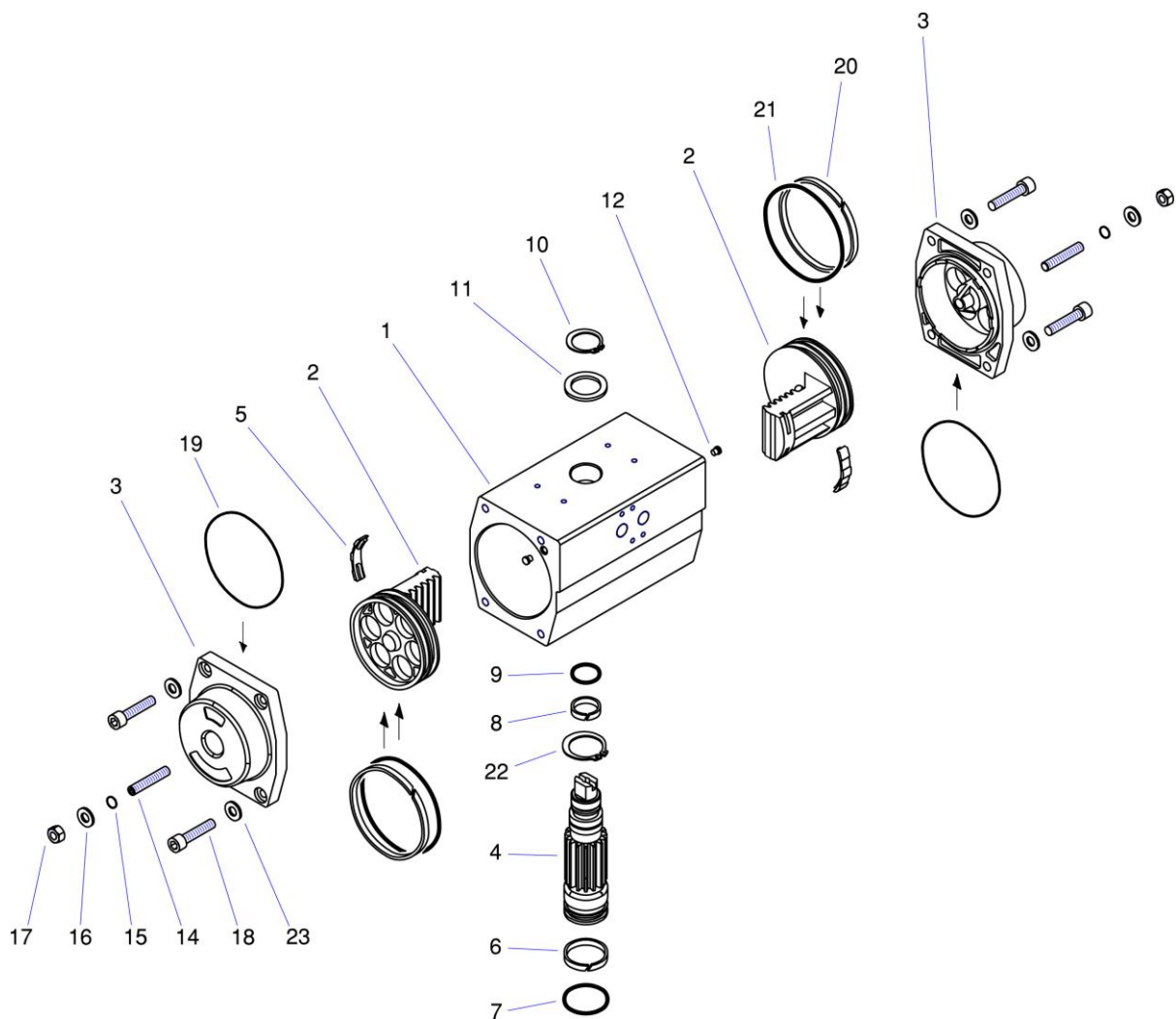

1. Remove the Allen screw (18) from the heads (3).
2. Remove the heads (3)
3. Rotate the stand (4) in anticlockwise so that the pistons (2) leak out from the body (1)
4. Remove the seeger (10) from the stand (4)
5. Extract the stand (4) from the body inferior side (1) performing a light pressure on the stand superior side (4).
6. Proceed to the change of the following parts:
 - On the body (1)**
 - n. 2 cover (12)
 - on the pistons (2)**
 - n. 2 O-ring (21)
 - n. 2 guide rings (20)
 - n. 2 guide pistons (5)
 - on the stand (4)**
 - n. 2 O-ring (7-9)
 - n. 2 guide rings (6-8)
7. With the completed change lubricate again the body internal surface, the stand and the guide rings with lithium grease NLG1 free from silicon compounds.
8. Proceed to the reassembly of all particulars following the opposite order respect the disassembly one.

9. Pay attention to the pistons insertion having care of pistons gear phase. Verify that when the pistons are inside, one against the other, the stand superior milling is placed as showed in the following diagram.

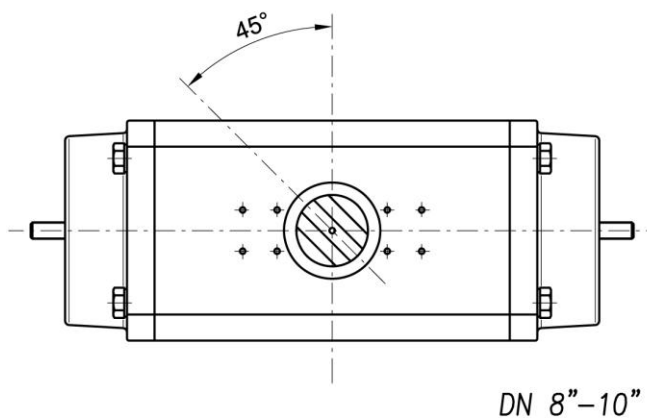
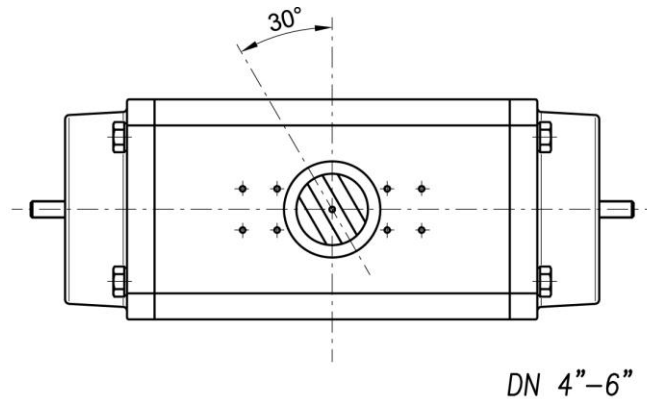

8. Storage

In the case of storage before the installation or storage for a long time we recommend to put the cocks in a fresh place (max 40°C) and airy safe from the direct sun light, from other heat sources and from humidity. Protect the cocks to avoid damages to the protective painting and consequent rust formation.

9. Disposal

The cocks before being disposed of must be disassembled from the plant respecting the following procedure:

- Open the cock and empty the pipes on which it is assembled
- Disconnect the cock from possible pneumatic or oildynamic lines,
- Disassemble the cock using adequate personal protection means (gloves, protection glasses, anti-accidental shoes, etc.)
- Reclaim the cock to avoid possible treated fluid leakages that could be cause of damage to people, things and ambient. In the same way the hydraulic oil will have to be removed contained in the hydraulic cylinder.
- After the reclaim it will be necessary to separate the recyclable materials (metallic parts, parts in plastic) from those to sell as special wastes (P.T.F.E. gaskets, parts in rubbish, etc) on the basis of the local actual standards.



The cock scrapping assembled and not reclaimed can provoke emissions with harmful consequences for the ambient.