



HPP NEWS

ET SERIES



HIGH PRESSURE PUMPS
POMPE AD ALTA PRESSIONE





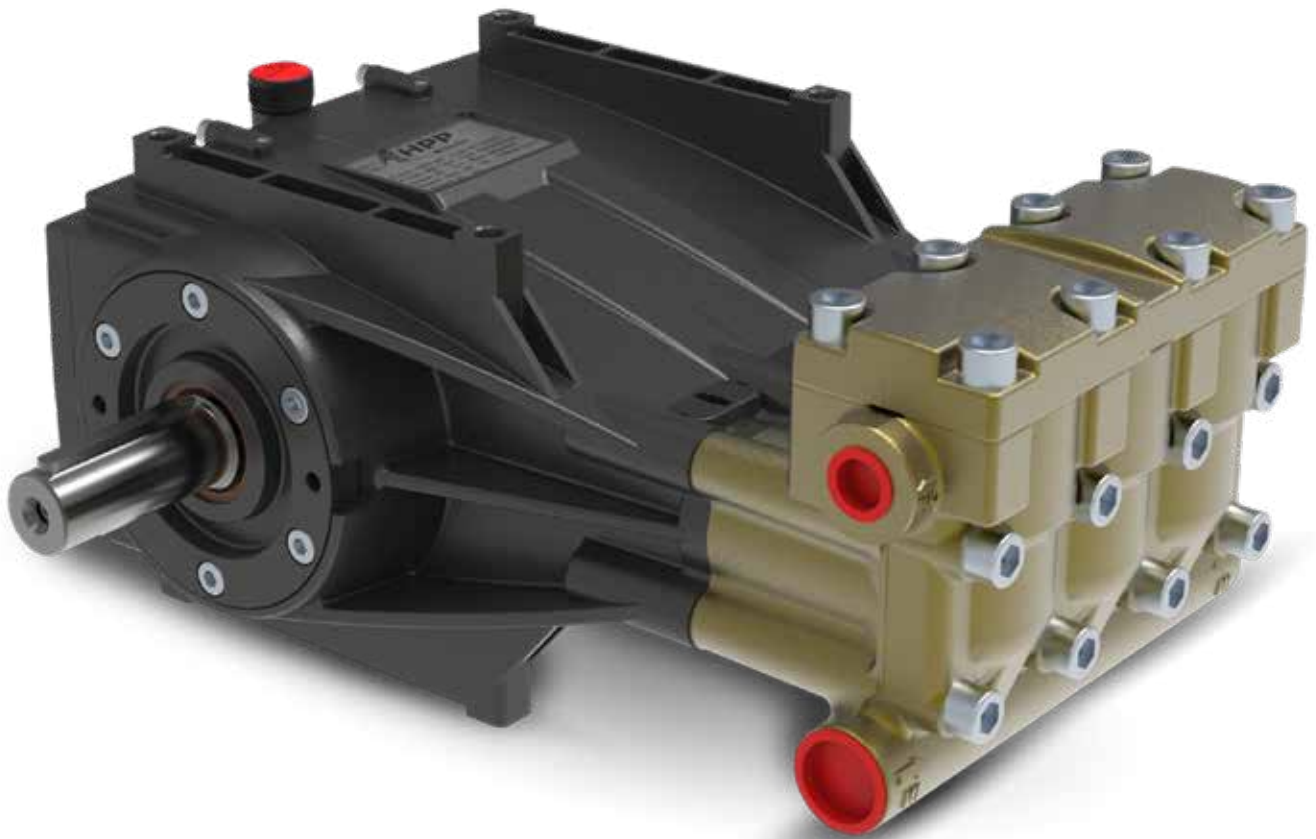

High performances, compact size
Alte prestazioni, dimensioni compatte



GENERAL FEATURES • CARATTERISTICHE GENERALI

- Triplex plunger pump in line
- Symmetric crankcase featuring top and bottom fixing for easy right to left shaft conversion
- Shaft support tapered roller bearings oversized for long duration
- **PATENTED** stainless steel suction/delivery valves featuring spherical design of sealing areas
- Seals: new high reliability high pressure seal with low-pressure lubrication and recirculation chamber
- Pump body: aluminium alloy
- Head: brass
- Camshaft: forged steel
- Splash lubrication
- Connecting rods: special antifriction alloy
- Guiding piston: stainless steel
- Solid ceramic plungers
- Steel valve cage
- Double sight glass oil
- Pompa volumetrica a tre pistoni in linea
- Carter simmetrico dotato di fissaggi sopra e sotto per sporgenza albero destra o sinistra
- Cuscinetti di supporto albero a rulli conici ampiamente sovradimensionati per una lunga durata
- Valvole aspirazione mandata **BREVETTATE** in acciaio inox a contatto sferico
- Nuove guarnizioni ad alta affidabilità con camera di ricircolo e lubrificazione in bassa pressione
- Corpo pompa in lega d'alluminio
- Testata in ottone
- Albero ad eccentrici in acciaio temprato
- Lubrificazione a sbattimento
- Bielle speciali in lega antisfregamento
- Pistone di guida in acciaio inox
- Pistoni tuffanti in ceramica integrale
- Doppio visore olio

TECHNICAL FEATURES • CARATTERISTICHE TECNICHE

Code	Model								
		rpm	l/min	US gpm	bar	psi	MPa	kW	HP
6928 0001	ET 30/500	1450	30	7,9	500	7252	50	29,3	39,8
6928 0002	ET 36/400	1750	36	9,5	400	5801	40	28,3	38,4

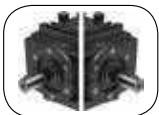
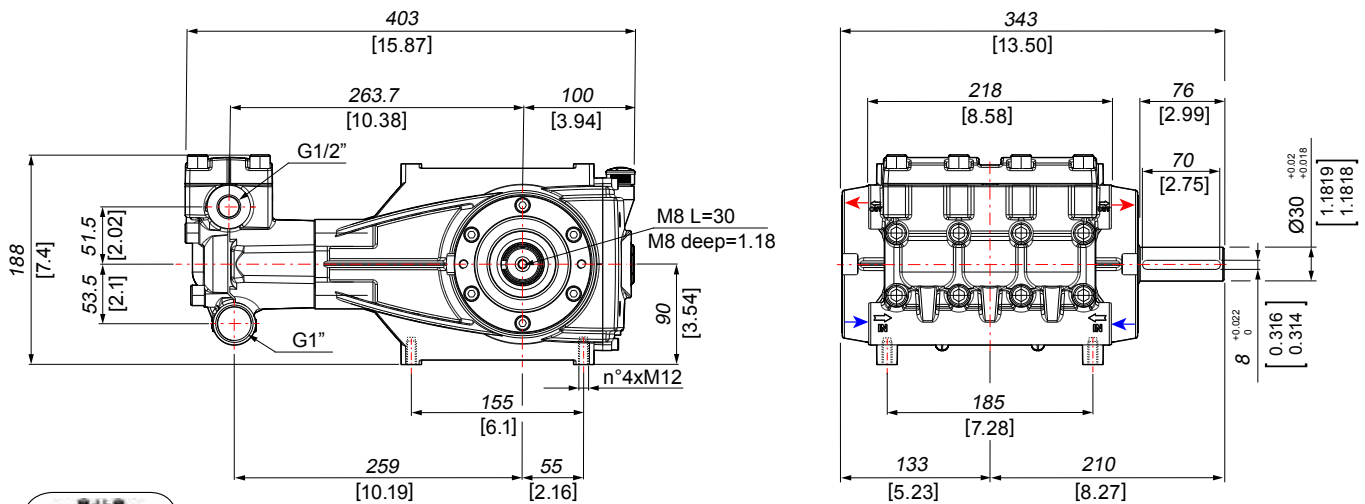

SYMMETRICAL - REVERSIBLE CARTER / CARTER SIMMETRICO - REVERSIBILE

COMPANY WITH
QUALITY SYSTEM
CERTIFIED BY DNV GL
= ISO 9001 =



www.hpp-pressurepumps.com



Comet Spa › via G. Dorso, 4 › 42124 Reggio Emilia › Italy
phone + 39 0522 386111 › www.comet-spa.com
Italia: vendite@comet-spa.com › Fax + 39 0522 386300
Export: export@comet-spa.com › Fax + 39 0522 386280

Distributed by: / Distribuito da:
P.T.C. Srl › via Mantegna, 4 - 42048 Rubiera (RE) - Italy
Phone: +39 0522/1932911 › Fax: +39 0522/1932922
mail: info@ptcitaliana.com › website: www.ptcitaliana.com