



P.A. – S.p.A. – EQUIPAGGIAMENTI TECNICI DEL LAVAGGIO

VIA MILANO, 13 – CASELLA POSTALE 115 – 42048 RUBIERA (REGGIO EMILIA) – ITALY
 Tel. +39 0522 623611 – Fax. +39 0522 629600 – R.E.A. RE 156319 – R.I. RE11535 – Mecc. RE 013446
 C.F. e P. IVA 01035950359 – Cap. Soc. i.v. € 750.000,00 – Codice Identificativo C.E.E. IT 01035950359
 ART. 2497 – BIS C.C. DIREZIONE E COORDINAMENTO BENETTI srl R.I. TRIB. DI RE 01480690351
 Web: <http://www.pa-etl.it> – E-mail: info@pa-etl.it



VS24-VS43 – Compensated safety valve INOX AISI 303

Technical manual: I 264

Indicated for use as a safety valve on pressure washers.

DN 15



- **60.1530.00** VS24 G1/2 F 280 bar – 28 MPa
- **60.1535.00** VS43 G1/2 F 400 bar – 40 MPa

- Sst body in aisi303.
- Sst internal parts.
- Parts in movement totally protected.
- Reliable intervention discharging the flow completely.

TECHNICAL SPECIFICATIONS

Max.flow rate 80 l/min - Max.temperature 90°C (1)

PART NUMBER	RATED PRESSURE PN	PERMISSIBLE PRESSURE	MINIMUM ADJUSTABLE PRESSURE	(2) PRESSURE INCREASE %	INLET	OUTLET	BYPASS	WEIGHT g
	bar - MPa	bar - MPa	bar - MPa					
60.1530.00	280 - 28	310 - 31	30 - 3	15 – 19% di PN	G1/2 F	G1/2 F	G1/2 F	840
60.1535.00	400 - 40	440 - 44	40 - 4	15– 19% di PN	G1/2 F	G1/2 F	G1/2 F	840

(1) The valve has been designed for a continuous use at water temperature of 60°C. It can resist for short periods at a maximum temperature of 90°C.

(2) **Pressure increase** = is the increase of pressure needed to the valve for discharging the max. flow when utilized at rated pressure..

Instruction manual, maintenance, installation, spare parts.

For a correct utilization, follow the directions of this manual

Re-print them on the use and maintenance booklet of the machine.

n. 12.9264.00

DIMENSIONAL DRAWING VS24

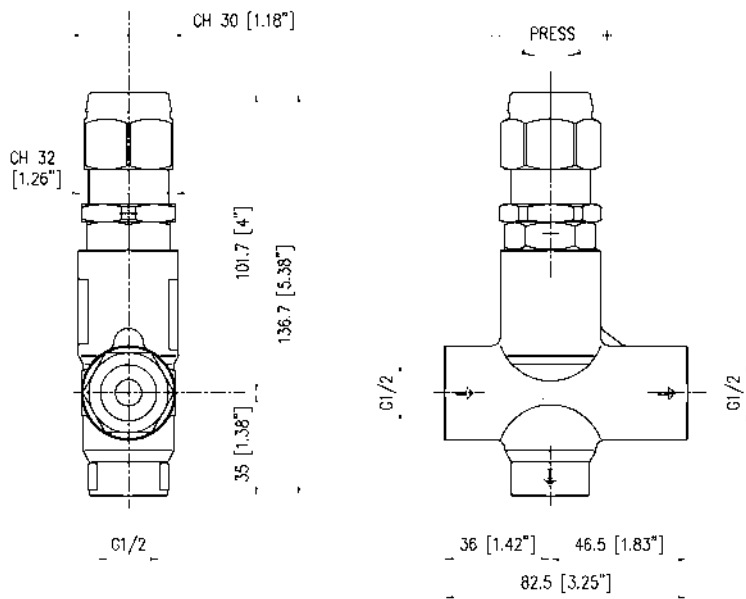

DIMENSIONAL DRAWING VS43

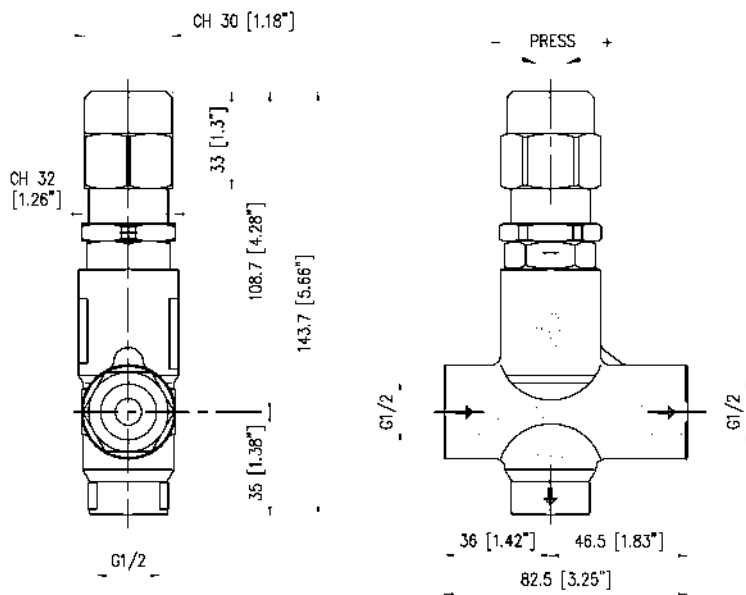

INSTRUCTIONS

SELECTION

This product is to be utilized with fresh clean water, even slightly additivated with normal detergents. For use involving different or corrosive liquids, contact the PA Technical department. Choose the safety valve in line with the data of nominal running (rated pressure, max flow and max temperature). In any case, no overpressure of the machine should exceed the permissible pressure rate imprinted on the valve.

INSTALLATION

This valve, on a machine that produces hot water, must be fitted **in front of the heat generator**. In the case where frequently combined with unloader valves, it has to be installed downstream from the valve in the channel that remains under pressure at gun closure or, in cold water systems, directly on the pump head.

DISCHARGE SYSTEM AND WATER ADDUCTION

It is advisable to lose the bypass discharge or to channel into a tank. If the pump is fed directly from the outside, it would be convenient to install a pressure reducer, before the pump itself, in order to avoid dangerous pressure spikes which can damage the ducts and the intake valves.

OPERATIONS

The valve adjusts the maximum pressure of the system by means of a piston which operates on a cone that, when normally positioned, shuts the bypass spot.

PRESSURE ADJUSTMENT/SETTING

The setting has to be made in such a way that the pressure setting is not superior to the maximum working pressure of the system and its accessories; in this manner the complete apparatus is protected by the numerous pressure increases which occur at gun closure or in case of malfunction. When the desired pressure is reached tighten the nut (pos 17) with the screw (pos 16) and a drop of paint to emphasize possible tampering or loosening.

PROBLEMS AND SOLUTIONS

PROBLEMS	PROBABLE CAUSES	SOLUTIONS
Valve cycles	<ul style="list-style-type: none"> - Air inside the system - Worn out seals - Clogged circuit 	<ul style="list-style-type: none"> - Flush out - Replace - Clean or widen passages
The valve does not reach pressure	<ul style="list-style-type: none"> - Seat/shutter/ball worn out - Impurities 	<ul style="list-style-type: none"> - Replace - Clean
Pressure drop	<ul style="list-style-type: none"> - Valve seat worn out - Air inside the system 	<ul style="list-style-type: none"> - Replace - Flush out
Water leakage from bypass Valve pounding	<ul style="list-style-type: none"> - O-ring seat damaged - Damaged seat - Impurities or worn out pump valves 	<ul style="list-style-type: none"> - Replace - Replace - Clean - Repalce

MAINTENANCE

In normal working conditions the safety valve should not open (no water discharge); if the valve is fitted on the pump head, it is in any case submitted to pressure cycles which have to be calculated for maintenance.

STANDARD: every 400 working hours (approximately 10000 working cycles of the system), check and lubricate the seals with water resistant grease.

SPECIAL: every 800 working hours (approximately 20000 working cycles of the system), control the wear of the seals and internal parts and, if necessary, replace with original PA parts taking care, during installation, to lubricate with water resistant grease.

Furthermore verify the absence of scale or dirt on the seat and the shutter.

ATTENTION: reassemble the valve in the correct manner paying special attention how to set the valve as described in the paragraph PRESSURE ADJUSTMENT/SETTING.

Maintenance has to be carried out by Specialized Technicians.

The manufacturer is not to be considered responsible for damage as a result from incorrect fitting and maintenance

Technical data, descriptions and illustrations are indicative and liable to modification without notice.

REGULATIONS : **See norm manual.**

The accessory hereby described is in accordance to the Norms and Directives applied on the Declaration of conformity For a correct utilization, follow the directions described in this manual and quoted on the Use and maintenance manual of the machine. For regularity, ask for the Original Conformity Declaration for the component used. The present manual is valid for all types of valves named **VS24-VS43**.



P.A. S.p.A.
Via Milano, 13
42048 Rubiera, Reggio Emilia - Italy
Tel +39.0522.623611
Fax +39.0522.629600
info@pa-etl.it

www.pa-etl.it



COMPANY WITH QUALITY MANAGEMENT
SYSTEM CERTIFIED BY DNV
= ISO 9001 =