

	EQUIPAGGIAMENTI TECNICI LAVAGGIO	TESTINA AUTOMOVENTE A42-R2 SELF ROTATING CLEANING HEAD 25.52XX.XX		<div style="border: 2px solid black; padding: 2px; display: inline-block;">4</div> 18
				

## SPECIFICHE TECNICHE SPECIFICATIONS

- PRESSIONE NOMINALE <i>RATED PRESSURE</i>	40÷140 bar – 4÷14 MPa (580÷2000 psi)
- PRESSIONE CONSENTITA <i>PERMISSIBLE PRESSURE</i>	160 bar – 16 MPa (2300 psi)
- PORTATA <i>FLOW RATE</i>	15÷50 l/min (4÷13.2 GPM)
- TEMPERATURA MASSIMA ACQUA <i>MAX WORKING TEMPERATURE</i>	0–90°C (32–195°F)
- PESO <i>WEIGHT</i>	3.27 Kg (115.3 oz)
- FREQUENZA ROTAZIONE ASSE PRINCIPALE <i>MAIN AXIS ROTATING SPEED</i>	110÷180 giri/min (RPM)
- TEMPO CICLO BREVE <i>SHORT CYCLE TIME</i>	13÷8 secondi
- TEMPO CICLO COMPLETO <i>FULL CYCLE TIME</i>	25.5÷15.5 secondi
- ATTACCO ALIMENTAZIONE ACQUA <i>INLET CONNECTION SIZE</i>	1/2 Gas
- ATTACCO UGELLI N°3 (UGELLI NON FORNITI) <i>N°3 NOZZLE CONNECTIONS (NOZZLES NOT SUPPLIED)</i>	1/8 NPT

### TESTINA AUTOMOVENTE

- Portata ridotta, alta pressione, elevata forza d'impatto.
- Velocità di rotazione indipendente dalla temperatura dell'acqua.
- Costruzione in acciaio inox e alluminio anticorrosivo anodizzato.
- Guarnizioni in viton e PTFE.
- Idonea per l'impiego nel settore alimentare.

### SELF ROTATING CLEANING HEAD

- Reduced flow, high pressure, strong cleaning impact.
- Rotating speed independent from water temperature.
- Structure in SST and anodised anticorrosive aluminium.
- Seals in viton and PTFE.
- Designed for the food industry.

### MISURE D'INGOMBRO OVERALL DIMENSIONS

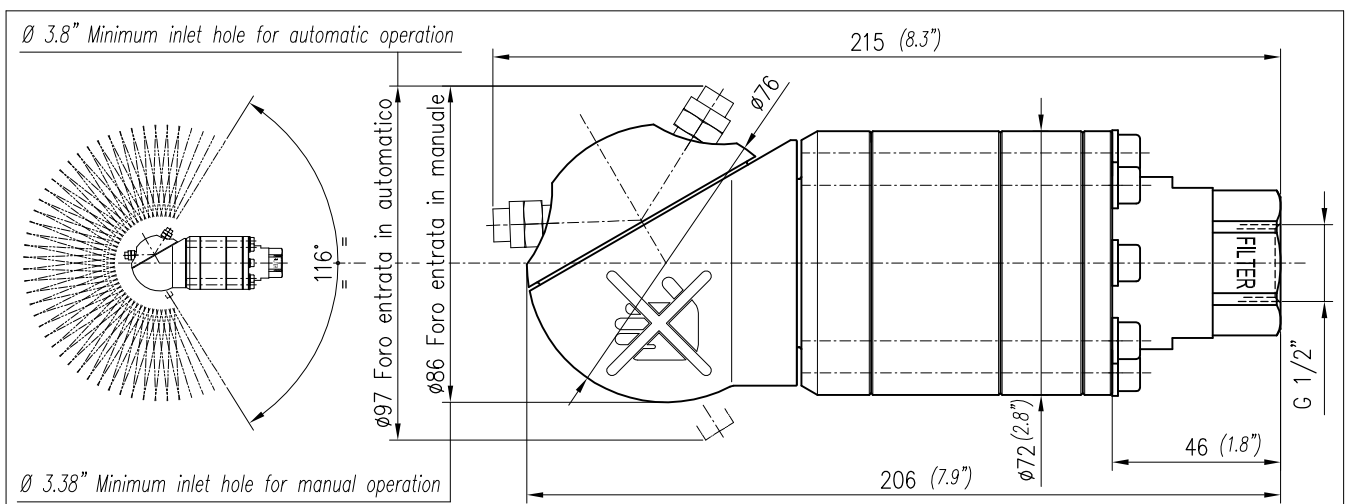

# CARATTERISTICHE TECNICHE TECHNICAL SPECIFICATIONS

A42-R2



21/12/09

- PRESSIONE NOMINALE <i>RATED PRESSURE</i>	40÷140 bar - 4 ÷14 MPa (580÷2000 psi)
- PRESSIONE CONSENTITA <i>PERMISSIBLE PRESSURE</i>	160 bar - 16 MPa (2300 psi)
- PORTATA <i>FLOW RATE</i>	15÷50 l/min (4÷13.2 USGp.m.)
- TEMPERATURA MASSIMA ACQUA <i>MAX WORKING TEMPERATURE</i>	0-90°C (32-195°F)
- PESO <i>WEIGHT</i>	3.27 Kg (115.3 oz)
- FREQUENZA ROTAZIONE ASSE PRINCIPALE <i>MAIN AXIS ROTATING SPEED</i>	110÷180 giri/min (RPM)
- ATTACCO ALIMENTAZIONE ACQUA <i>INLET CONNECTION SIZE</i>	1/2 Gas
- ATTACCO UGELLI N°3 <i>NOZZLES CONNECTION N°3</i>	1/8 NPT

TEMPO PER UN CICLO COMPLETO DI LAVAGGIO  
(47 GIRI DELL'ASSE PRINCIPALE)

TIME FOR A COMPLETE CLEANING CYCLE  
(47 MAIN AXIS REVOLUTIONS)

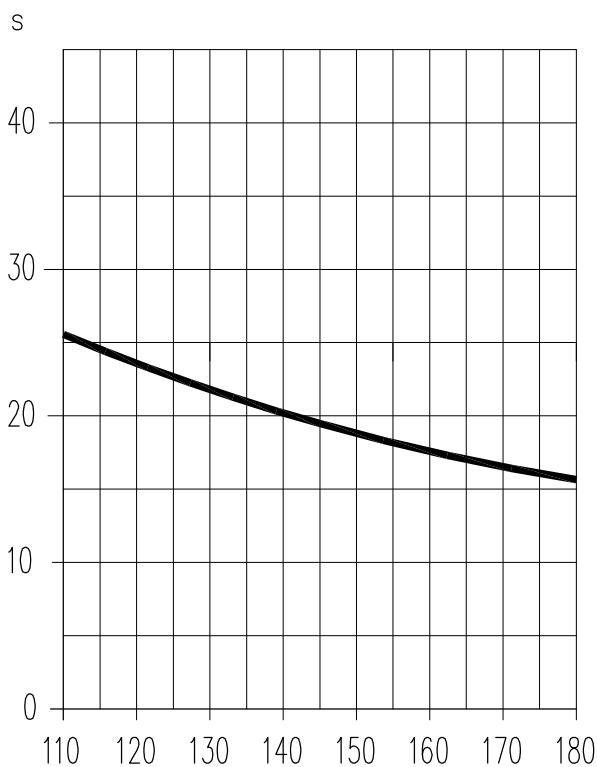

VELOCITA' DI ROTAZIONE giri/min  
ROTATING SPEED RPM

TEMPO PER UN CICLO BREVE DI LAVAGGIO  
(23,5 GIRI DELL'ASSE PRINCIPALE)

TIME FOR A SHORT CLEANING CYCLE  
(23,5 MAIN AXIS REVOLUTIONS)

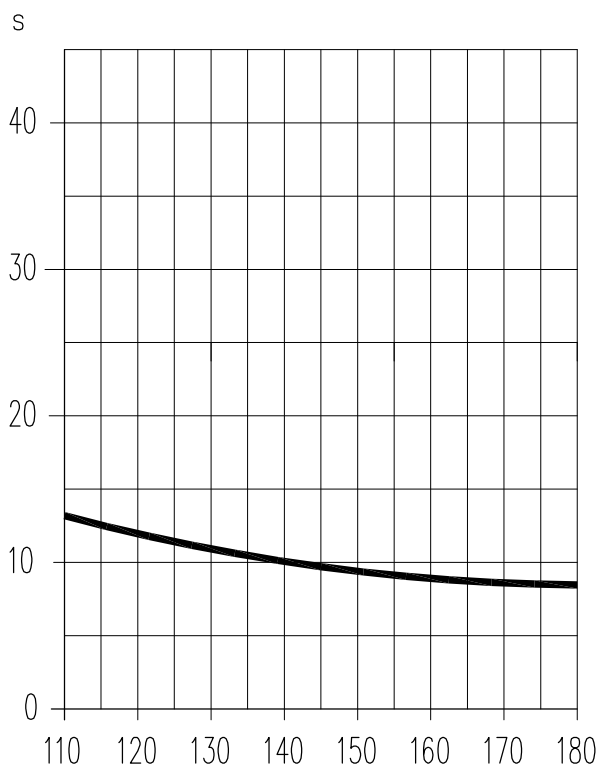

VELOCITA' DI ROTAZIONE giri/min  
ROTATING SPEED RPM

-D1-



**P.A. – S.p.A. – EQUIPAGGIAMENTI TECNICI DEL LAVAGGIO**

VIA MILANO, 13 – CASELLA POSTALE 115 – 42048 RUBIERA (REGGIO EMILIA) – ITALY  
 Tel. +39 0522 623611 – Fax. +39 0522 629600 – R.E.A. RE 156319 – R.I. RE11535 – Mecc. RE 013446  
 C.F. e P. IVA 01035950359 – Cap. Soc. i.v. € 750.000,00 – Codice Identificativo C.E.E. IT 01035950359  
 ART. 2497 – BIS C.C. DIREZIONE E COORDINAMENTO BENETTI srl R.I. TRIB. DI RE 01480690351  
 Web: <http://www.pa-etl.it> – E-mail: [info@pa-etl.it](mailto:info@pa-etl.it)



**Dichiarazione di conformità**  
**Declaration of conformity**

<b>Attrezzatura – Equipment:</b>		<b>ACCESSORIO A PRESSIONE PRESSURE EQUIPMENT</b>	
<b>Modello – Type:</b>		<b>A42R / A42R2</b>	
<b>Fluido – Fluid:</b>		<b>ACQUA CALDA E DETERGENTI HOT WATER AND DETERGENTS</b>	
<b>Gruppo fluidi: Group of Fluid:</b>	-----	<b>Temperatura min. e max. ammissibile Permissible Temperature (min/max)</b>	<b>0 ÷ 90°C</b>

**Procedura di valutazione della conformità**  
**Conformità Assessment Procedure Followed**

<b>Categoria: Category:</b>	-----	<b>Modulo: Module:</b>	-----
<b>Organismo notificato - Notified Body:</b>		-----	
<b>Attestato CE del tipo - EC Type - Examination Certificate:</b>		-----	
<b>Marcatura CE del fabbricante - Manufacturer's CE Marking:</b>		-----	
<b>Organismo Notificato per il Sistema Qualità: Notified Body for Assessment of Quality System:</b>		-----	
<b>Organismo di certificazione per il Sistema di Qualità: Notified Body for Certification of Quality System:</b>		<b>DNV</b>	
<b>Norme europee applicate: Harmonized Standards applied :</b>		<b>UNI 9335, CEI EN 60335-2-79, UNI EN 1829</b>	
<b>Altre Direttive applicate: Other Directive applied:</b>			
<b>Codici di calcolo: Design Calculations Made:</b>			

<b>Libretto uso e manutenzione presente nel sito web Operation and Maintenance Manual to be found on Website</b>	<b>Il Fabbricante PA SpA The Manufacturer PA SpA</b>	
--	--	--

25.5200.20 A42 R2 Test.angolare 2 stadi, 20 l/min

25.5200.24 A42 R2 Test.semov., 25 l/min

25.5200.28 A42 R2 Test.semov., 30 l/min

25.5200.33 A42 R2 Test.semov., 50 l/min

25.5200.34 A42 R2 Test.semov., 40 l/min

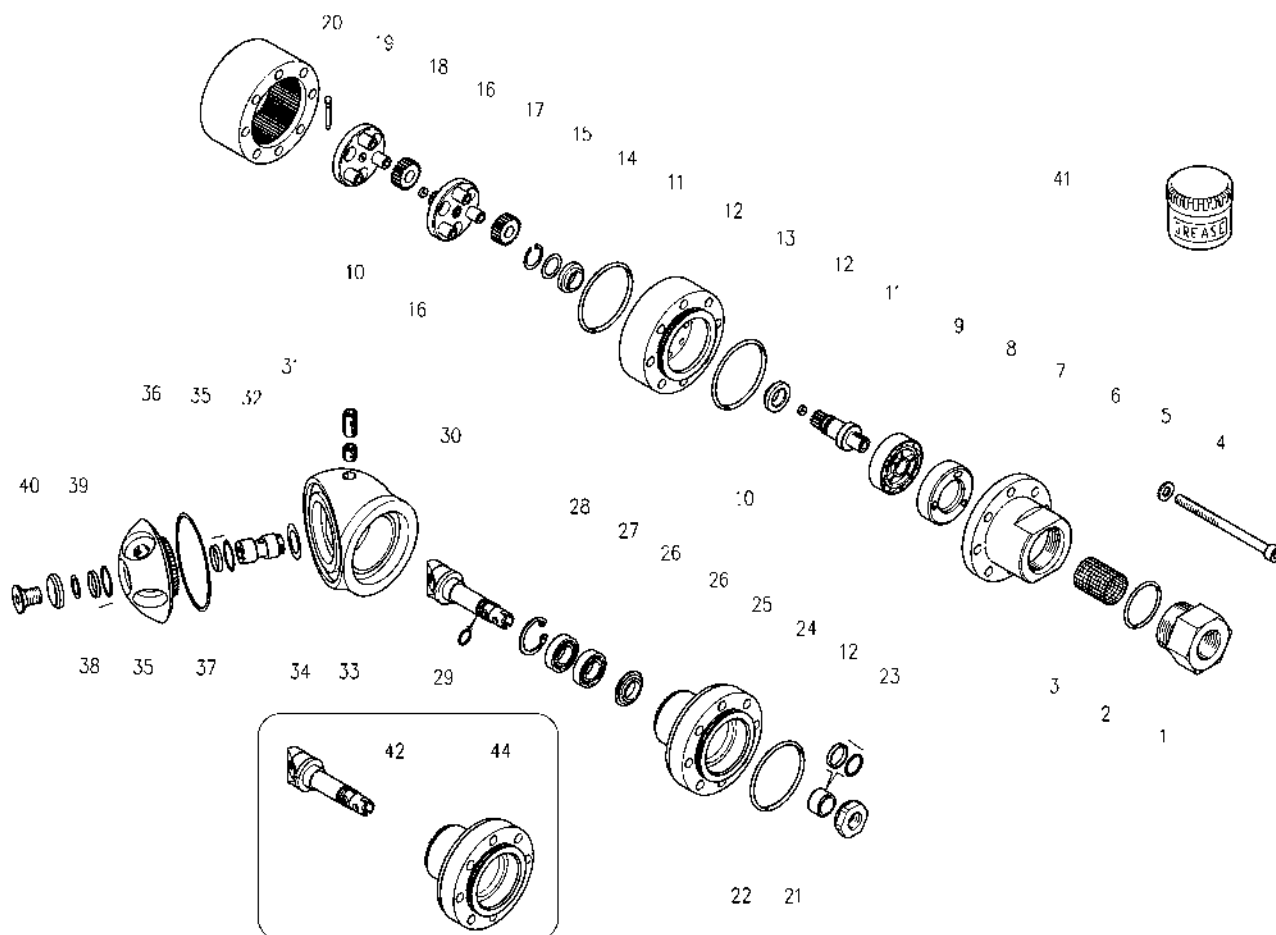

FINO ALLA MATRICOLA 409 COMPRESA

Pos.	Codice	Descrizione	Q.tà	K1	K2	K3	K4	Pos.	Codice	Descrizione	Q.tà	K1	K2	K3	K4
1	80.0534.51	Racc. entrata G1/2F inox	1				3	21	80.0504.51	Ghiera M12x1 inox	1				1
2	10.3077.10	An.OR 1,78x28,3 mm Vi 70	1	•			10	22	80.0509.51	Boccola porta guarnizioni inox	1		•		3
3	28.0116.53	Filtro d.21,5mm 38mesh-700µ in.	1		•		5	23	10.2035.16	Guarn.16x21x2,1 mm +Or Vit.	1	•		•	5
4	16.1908.00	Vite DIN912 M6x80 mm inox	8				10	24	80.0552.51	Ingranag.fisso z:45 inox.	1				1
5	14.3569.05	Rosetta 6,4x11x1mm inox	8				10	25	80.0550.31	Distanziale, 12,3x27,5mm ottone	1				5
6	80.0533.51	Corpo entrata inox	1				1	26	11.4412.28	Cuscinetto 12x28x8 mm - 2RS1 inox	2		•		3
7	80.0514.51	An. Iniettore 3x2 mm inox (1)	1				1	27	10.1011.05	An. elast. I 28 inox	1		•		10
7	80.0519.51	An. Iniettore 3x2,4 mm inox (2)	1				1	28	80.0551.51	Albero di trasmissione inox.	1				1
7	80.0515.51	An. Iniettore 3x2,6 mm inox (3)	1				1	29	10.3019.10	An.OR 1,5x9,5 mm Vi 70	1	•			10
7	80.0525.51	An. Iniettore 5x3,3 mm inox (4)	1				1	30	80.0523.41	Calotta sferica A42R/R2 Al.	1				1
7	80.0526.51	An. Iniettore 4x3,2 mm inox (5)	1				1	31	16.2225.00	Grano DIN913 M8x16 mm inox	1				10
8	80.0512.84	Turbina plast.	1				3	32	16.2221.00	Grano DIN914 M8x8 mm inox	1				10
9	80.0540.22	Albero planetario completo	1				1	33	80.0513.53	An. rasamento 15,4x23x0,3mm inox	1				5
10	80.0536.38	An. Rasamento 1,2x6x2mm bronzo **	2		•		3	34	80.0507.51	Perno M12x1M-M8 F inox	1				3
11	80.0548.84	Boccola	2		•		3	35	10.2035.00	Guarn. stelo 15x20x2 mm +OR	2		•		4
12	10.3034.10	An.OR 1,5x46 mm Vi 70	3		•		10	36	10.3270.10	An.OR 3,53x59,92 mm Vi 70	1		•		10
13	80.0532.51	Flangia entrata acc.inox	1				1	37	80.0539.22	Portaug.3x1/8Npt Al+ingr.z.47	1				1
14	80.0510.53	An. rasamento 12,3x17x0,5mm inox	1				5	38	80.0505.53	An. rasamento 8,3x14x0,3mm inox	1				5
15	10.0999.05	An. elast. E 12 inox	1		•		10	39	80.0015.51	Rosetta svas. 8,5x22x4,5mm inox	1				3
16	80.0501.38	Satellite z.24 bronzo	6		•		3	40	16.1954.12	Vite DIN7991 M8x12 mm inox	1				10
17	80.0541.22	Portasatelliti+3 perni+ingran. Z.12 inox	1				1	41	14.6550.00	Grasso al teflon x30 g.>no Epdm **	1				2
18	80.0538.22	Portasatelliti+3 perni inox+ spina	1				1	42	80.0506.51	Albero di trasmissione inox	1				1
19	80.0545.31	Spina fusibile D.3mm **	1		•		5	44	80.0520.51	Pignone z.45 inox	1				1
20	80.0524.51	Corona z.60 per testina 2 stadi inox	1				1								

\*\* Su richiesta

Kit	Codice	Descrizione	Q.tà
K1	25.5181.24	Kit ric.guarn. A42R 6x1pz.	1
K2	25.5182.24	Kit ric. A42/43/44 7x1pz.	1
K3	25.5183.24	A42/43/44 - kit ric.bocc+guarn.2x1	1

(1) 25.5200.20 (2) 25.5200.24 (3) 25.5200.28 (4) 25.5200.33 (5) 25.5200.34

Aggiornato al 04/02/2017

25.5200.20 A42-R2 Tank clean.,2-stage, 20 l/min  
 25.5200.24 A42-R2 Tank clean.,s/prop., 25 l/min  
 25.5200.28 A42-R2 Tank clean.,s/prop., 30 l/min

25.5200.33 A42-R2 Tank clean.,s/prop., 50 l/min  
 25.5200.34 A42-R2 Tank clean.,s/prop., 40 l/min

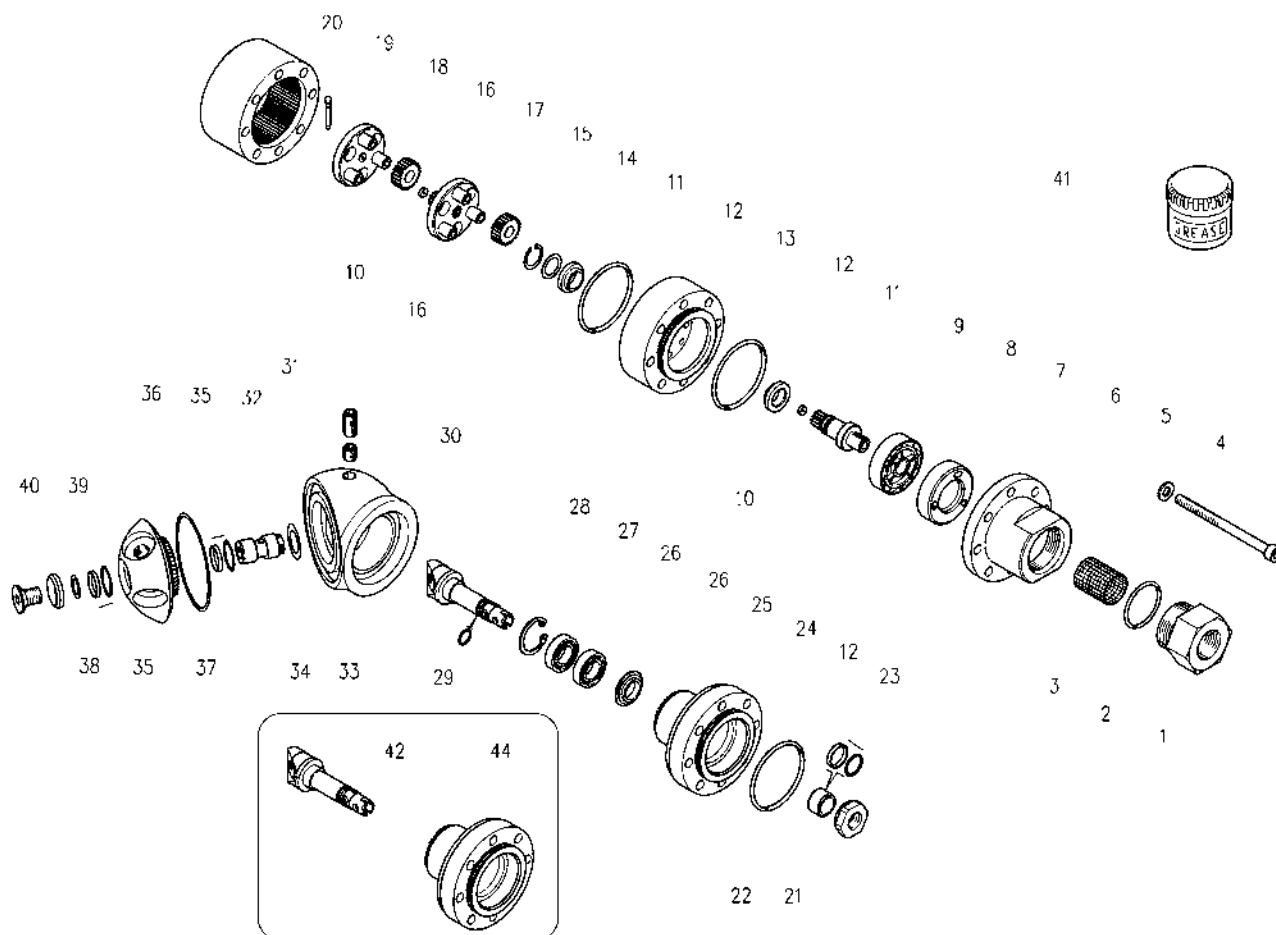

FINO ALLA MATRICOLA 409 COMPRESA

Pos.	P/N	Description	Q.ty	K1	K2	K3	K4	Pos.	P/N	Description	Q.ty	K1	K2	K3	K4
1	80.0534.51	Inlet coupl., 1/2Bsp F Sst.	1				3	21	80.0504.51	Ring nut, M12x1 Sst.	1				1
2	10.3077.10	O-ring, 1,78x28,3 mm Vi 70	1	•			10	22	80.0509.51	Seal holding bushing, Sst.	1		•		3
3	28.0116.53	Strainer 21,5mm 38mesh-700µm sst.	1				5	23	10.2035.16	Seal, 16x21x2,1 mm+Or.iVit.	1	•		•	5
4	16.1908.00	Screw, DIN912 M6x80 mm Sst.	8				10	24	80.0552.51	Pinion z:45 sst.	1				1
5	14.3569.05	Washer, 6,4x11x1 mm Sst.	8				10	25	80.0550.31	Spacer ring, 12,3x27,5 brass	1				5
6	80.0533.51	Inlet housing, Sst.	1				1	26	11.4412.28	Ball-bearing, 12x28x8 mm - 2RS1 Sst.	2	•			3
7	80.0514.51	Ring injector, 3x2 mm Sst. (1)	1				1	27	10.1011.05	Snap ring, I 28 Sst.	1	•			10
7	80.0519.51	Ring injector, 3x2,4 mm Sst. (2)	1				1	28	80.0551.51	Propeller shaft, Sst.	1				1
7	80.0515.51	Ring injector, 3x2,6 mm Sst. (3)	1				1	29	10.3019.10	O-ring, 1,5x9,5 mm Vi 70	1	•			10
7	80.0525.51	Ring injector, 5x3,3 mm Sst. (4)	1				1	30	80.0523.41	Spherical cap -A42R/R2, Al.	1				1
7	80.0526.51	Ring injector, 4x3,2 mm Sst. (5)	1				1	31	16.2225.00	Set screw, DIN913 M8x16 mm Sst.	1				10
8	80.0512.84	Turbine, plast.	1				3	32	16.2221.00	Set screw, DIN914 M8x8 mm Sst.	1				10
9	80.0540.22	Planetary shaft, complete	1				1	33	80.0513.53	Shim ring, 15,4x23x0,3mm Sst.	1				5
10	80.0536.38	Shim ring, 1,2x6x2mm brz **	2		•		3	34	80.0507.51	Pin, M12x1M-M8F Sst.	1				3
11	80.0548.84	Bushing ring	2		•		3	35	10.2035.00	Stem seal, 15x20x2 mm +O-ring	2	•			4
12	10.3034.10	O-ring, 1,5x46 mm Vi 70	3	•			10	36	10.3270.10	O-ring, 3,53x59,92 mm Vi 70	1	•			10
13	80.0532.51	Sst. inlet flange	1				1	37	80.0539.22	Nzl hold,3x1/8Npt Al+gear z.47	1				1
14	80.0510.53	Shim ring, 12,3x17x0,5mm Sst.	1				5	38	80.0505.53	Shim ring, 8,3x14x0,3mm Sst.	1				5
15	10.0999.05	Snap ring, E 12 Sst.	1	•			10	39	80.0015.51	C/sunk washer, 8,5x22x4,5mm Sst.	1				3
16	80.0501.38	Planetary gear, z.24 brz	6	•			3	40	16.1954.12	Screw, DIN7991 M8x12 mm Sst.	1				10
17	80.0541.22	Plan. gear holder+3 pins+gear, Sst.	1				1	41	14.6550.00	Teflon grease x30g.>no Epdm **	1				2
18	80.0538.22	Planetary gear holder+3 pins, Sst.+1 pin	1				1	42	80.0506.51	Propeller shaft, Sst.	1				1
19	80.0545.31	Fuse plug, D.3mm **	1	•			5	44	80.0520.51	Pinion, z.45 Sst.	1				1
20	80.0524.51	Ring gear z.60, 2-stage cleaner, sst.	1				1								

\*\* On request

Kit	P/N	Description	Q.ty
K1	25.5181.24	Seals Spares Kit - A42R 6x1pcs.	1
K2	25.5182.24	Spares Kit - A42/43/44 7x1pcs.	1
K3	25.5183.24	Spares Kit - A42/43/44 2x1pcs.	1

(1) 25.5200.20 (2) 25.5200.24 (3) 25.5200.28 (4) 25.5200.33 (5) 25.5200.34

Last updated 04/02/2017







P.A. S.p.A.  
Via Milano, 13  
42048 Rubiera, Reggio Emilia - Italy  
Tel +39.0522.623611  
Fax +39.0522.629600  
[info@pa-etl.it](mailto:info@pa-etl.it)

[www.pa-etl.it](http://www.pa-etl.it)



COMPANY WITH QUALITY MANAGEMENT  
SYSTEM CERTIFIED BY DNV  
= ISO 9001 =