



EQUIPAGGIAMENTI
TECNICI
LAVAGGIO

25.1520.12
LANCIA A SCHIUMA LS3-1 D=1.25
FOAM INJECTOR LS3

20/05/2002

CARATTERISTICHE TECNICHE - SPECIFICATIONS

- PRESSIONE NOMINALE RATED PRESSURE	160 bar - 16 MPa (2300 psi)
- PRESSIONE CONSENTITA PERMISSIBLE PRESSURE	180 bar - 16 MPa (2600 psi)
- PORTATA MASSIMA MAX FLOW RATE	VEDI DIAGRAMMA (SEE CHART BELOW)
- TEMPERATURA MASSIMA MAX WORKING TEMPERATURE	60° C (140° F)
- UGELLO NOZZLE	ø1.25 [0.049"] ø1.4 [0.055"]

- REGOLATORE MICROMETRICO PER UN DOSAGGIO PRECISO
MICROMETRICAL REGULATOR FOR CORRECT DOSING
- FILTRO INTERNO INOX PER UNA SCHIUMA DI QUALITA'
INTERNAL SST FILTER FOR A QUALITY FOAM
- ROBUSTA COSTRUZIONE IN OTTONE E ACCIAIO INOX
STRONG BRASS & SST STRUCTURE
- ASPIRAZIONE ARIA LATO ANTERIORE
FRONT SIDE AIR INTAKE
- CAPPuccio A TENUTA PER EVITARE IL RITORNO DI SCHIUMA
SEALED CAP TO PREVENT FOAM RETURN

Attenzione: risciacquare con acqua pulita al termine di ogni utilizzo giornaliero allo scopo di mantenere pulito il filtro schiuma e consentire un corretto funzionamento.

Warning: rinse with clear water after use every day to keep foam strainer clean and grant smooth functioning.



MISURE D'INGOMBRO - OVERALL DIMENSIONS

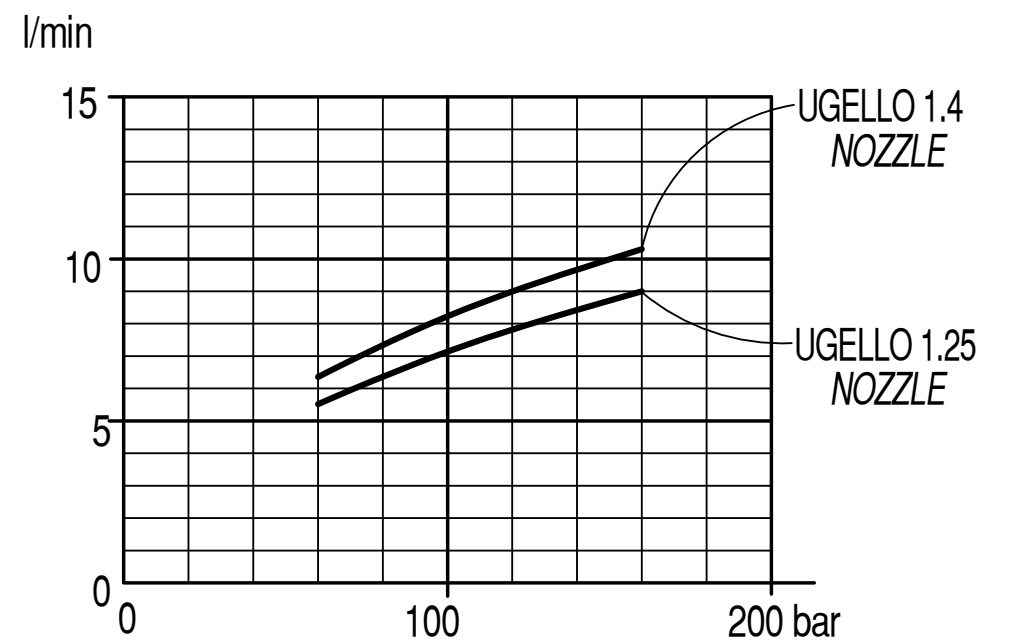
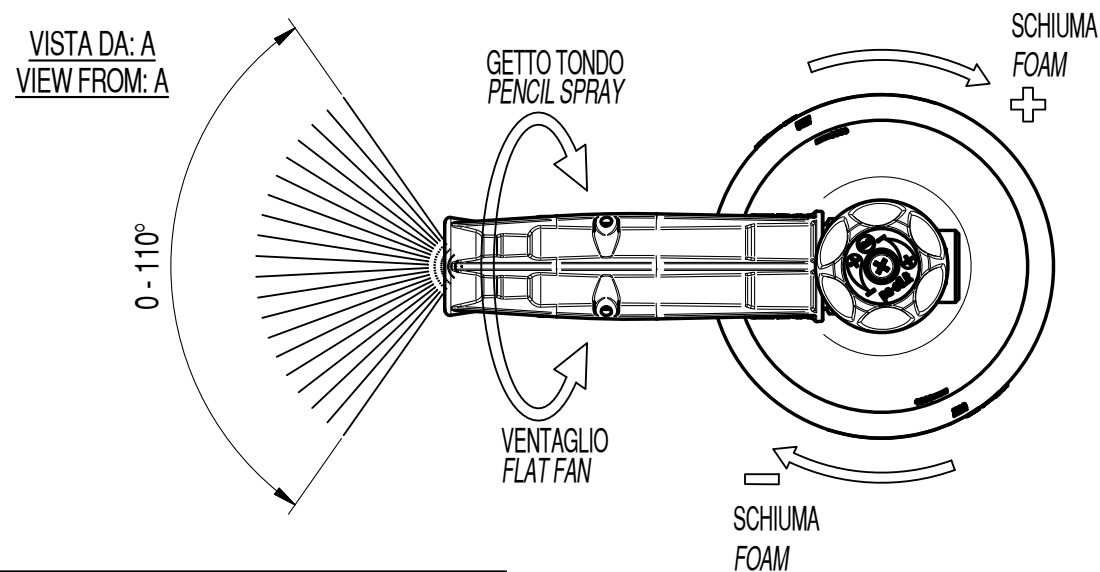

CODICE (CODE)	UGELLO mm (NOZZLE inch.)
25.1520.12	1.25 [0.049"]
25.1520.14	1.4 [0.055"]

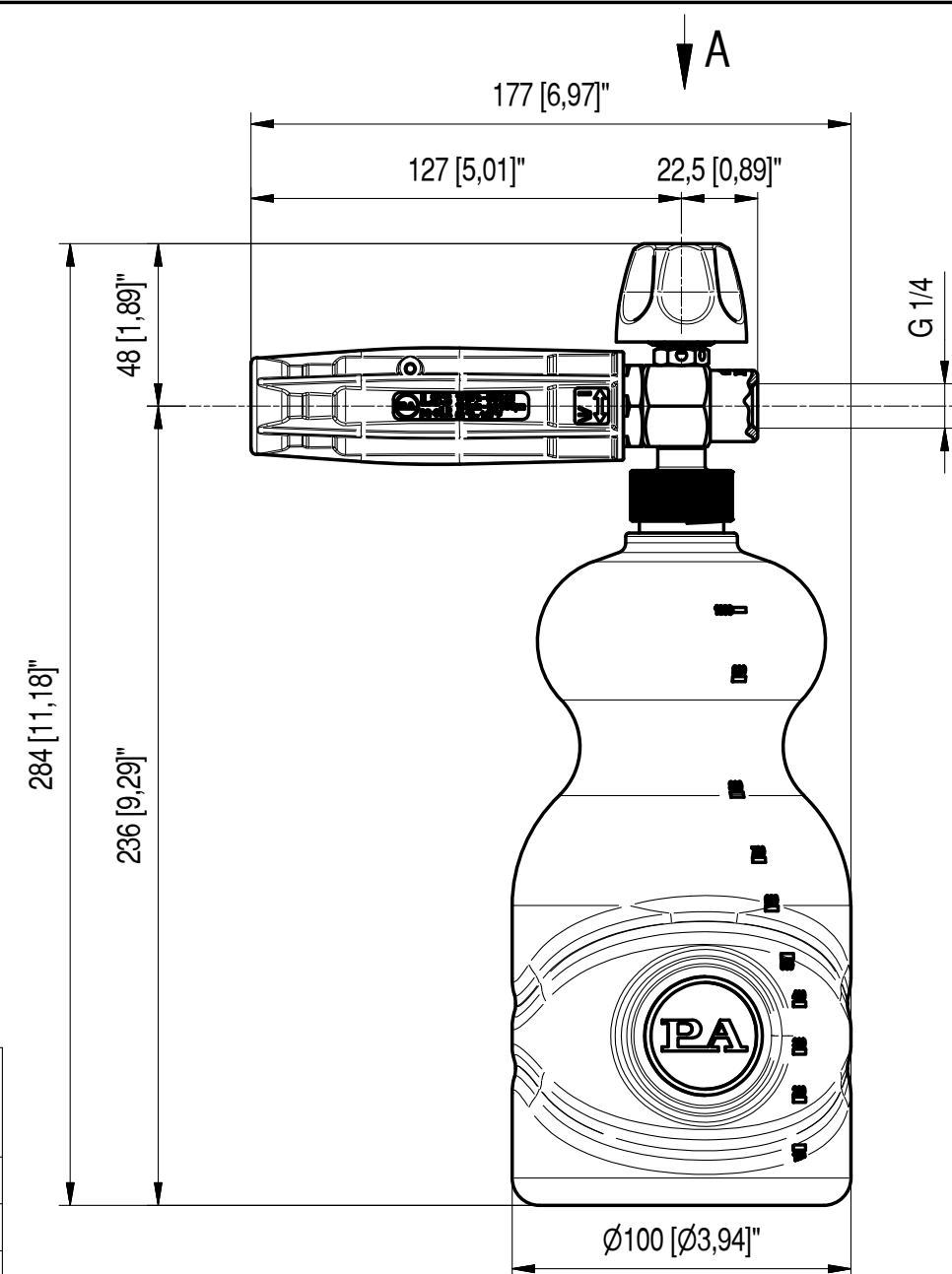

25.1520.12 LS3.2 Lan.schiu.1,25mm+serbat. 1L

25.1520.14 LS3.1 Lancia schiuma 1,4mm+serbatoio 1L

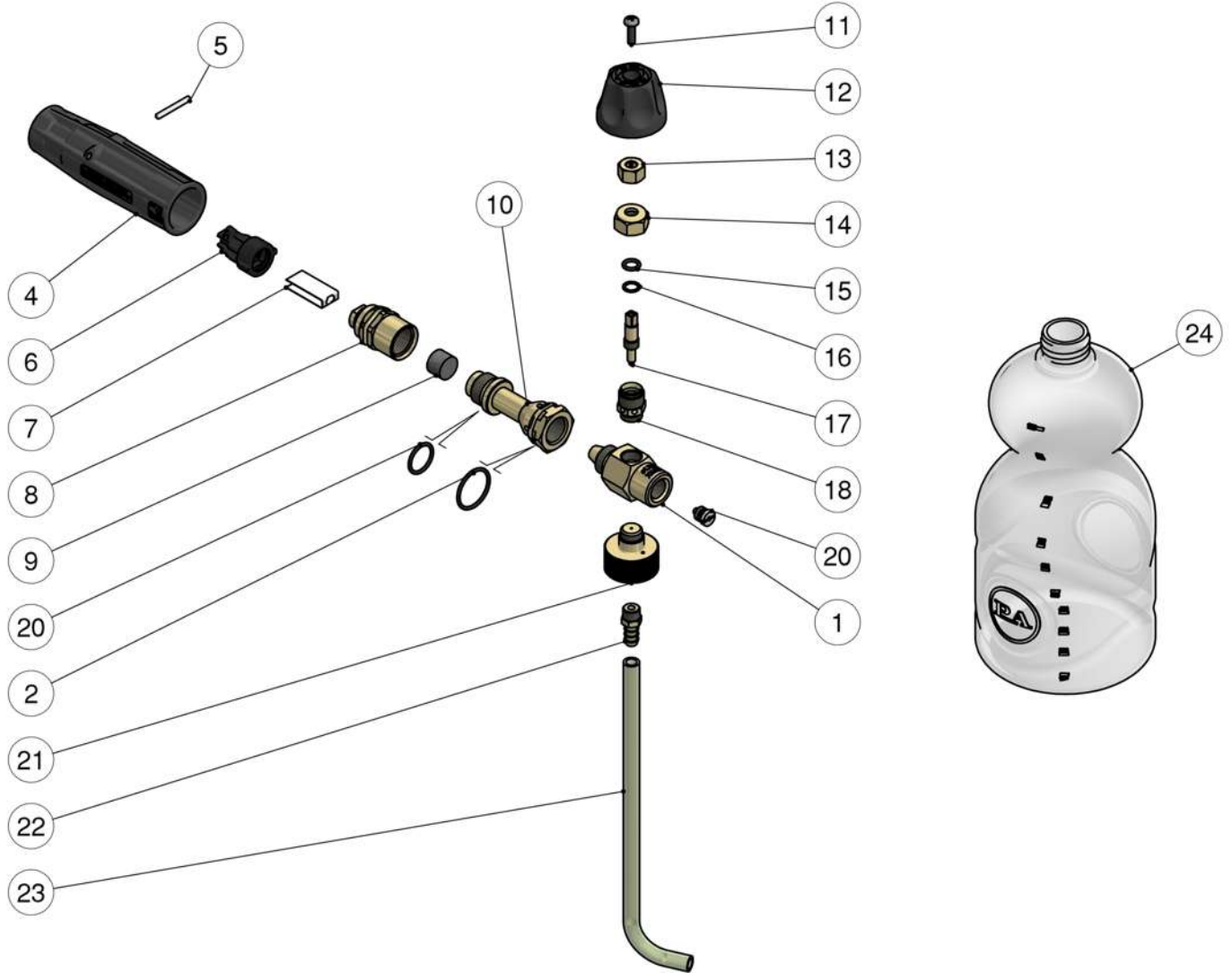

Pos.	Codice	Descrizione	Q.tà	K1	K2	K3	K4		Pos.	Codice	Descrizione	Q.tà	K1	K2	K3	K4	
1	25.1503.31	Corpo eiettore	1					3	14	29.0938.31	Ghiera M14x1 ott.	1					10
2	10.3072.50	An.OR 1,78x21,95 mm	1					10	15	10.3052.00	An.OR 1,78x6,75 mm	1					25
3	10.3066.00	An.OR 1,78x15,6 mm	1					10	16	29.0940.51	Rosetta 7x9,5x0,7 mm inox	1					10
4	25.1018.84	Manopola ugello nera	1					10	17	25.1504.31	Perno	1					5
5	15.1041.00	Spina cil. 3x25 mm inox	1					10	18	25.1502.31	Raccordo portaspillo	1					5
6	25.0952.84	Corpo deflettore	1					10	19	15.3808.12	Targhetta LS3	1					10
7	25.1020.53	Deflettore inox	1					10	20	21.0223.51	Ugello M8x1 - 1,25 mm inox (1)	1					5
8	25.1522.31	Corpo eiettore	1					3	20	21.0226.51	Ugello M8x1 - 1,4 mm inox (2)	1					5
9	25.1512.51	Filtro pressato 14x10 mm inox	1					10	21	25.1505.31	Racc. portaserbatoio	1					3
10	25.1521.31	Corpo anteriore eiettore	1					3	22	29.0103.31	Nipplo ott.G1/8M+ptgm.8mm	1					10
11	16.1840.00	Vite DIN7985 M4x14 mm zinc.	1					10	23	16.0521.00	Tubo 6x9 L.255 mm PVC	1					5
12	25.1535.84	Manopola PA nera v.2	1					10	24	14.6502.00	Serbatoio l.1	1					10
13	29.0924.31	Dado scanalato ott.	1					10									

(1) 25.1520.12 (2) 25.1520.14

25.1520.12 LS3.2 Foamer 1,25mm+1L tank

25.1520.14 LS3.1 Foamer 1,4mm + tank 1L

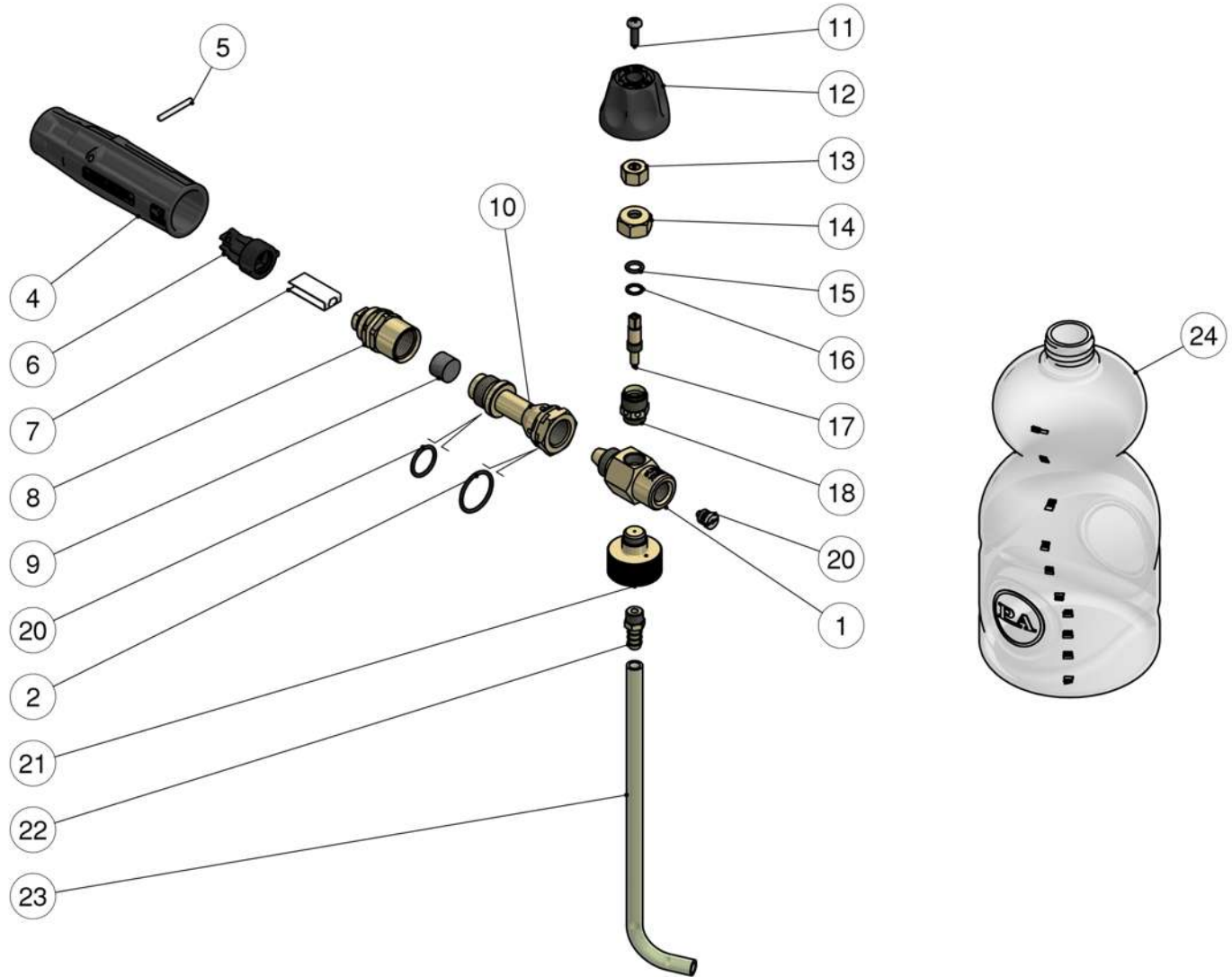

Pos.	P/N	Description	Q.ty	K1	K2	K3	K4		Pos.	P/N	Description	Q.ty	K1	K2	K3	K4	
1	25.1503.31	Injector housing	1					3	14	29.0938.31	Ring nut, M14x1 brass	1					10
2	10.3072.50	O-ring, 1,78x21,95 mm	1					10	15	10.3052.00	O-ring, 1,78x6,75 mm	1					25
3	10.3066.00	O-ring, 1,78x15,6 mm	1					10	16	29.0940.51	Washer, 7x9,5x0,7 mm Sst.	1					10
4	25.1018.84	Nozzle knob, black	1					10	17	25.1504.31	Pin	1					5
5	15.1041.00	Parallel pin, 3x25 mm Sst.	1					10	18	25.1502.31	Piston holder	1					5
6	25.0952.84	Deflector housing	1					10	19	15.3808.12	Label LS3	1					10
7	25.1020.53	Sst deflector	1					10	20	21.0223.51	Nozzle, M8x1 - 1,25 mm Sst. (1)	1					5
8	25.1522.31	Injector housing	1					3	20	21.0226.51	Nozzle, M8x1 - 1,4 mm Sst. (2)	1					5
9	25.1512.51	Pressed strainer, 14x10 mm Sst.	1					10	21	25.1505.31	Tank holder	1					3
10	25.1521.31	Front injector housing	1					3	22	29.0103.31	Nipple, brass, 1/8M Bsp+8mm h.barb	1					10
11	16.1840.00	Screw, DIN7985 M4x14 mm z.pl.	1					10	23	16.0521.00	Hose, 6x9 L.255 mm PVC	1					5
12	25.1535.84	Knob, PA black v.2	1					10	24	14.6502.00	Tank, l.1	1					10
13	29.0924.31	Groove nut, brass	1					10									

(1) 25.1520.12 (2) 25.1520.14



P.A. S.p.A.
Via Milano, 13
42048 Rubiera, Reggio Emilia - Italy
Tel +39.0522.623611
Fax +39.0522.629600
info@pa-etl.it

www.pa-etl.it



COMPANY WITH QUALITY MANAGEMENT
SYSTEM CERTIFIED BY DNV
= ISO 9001 =