



EQUIPAGGIAMENTI
TECNICI
LAVAGGIO

25.12XX.XX
ST3/ST4 UGELLI STURATUBO
ST3/ST4 DRAIN CLEANING NOZZLE



4

05/05/11

CARATTERISTICHE TECNICHE - SPECIFICATIONS

- PRESSIONE NOMINALE RATED PRESSURE	350 bar - 35 MPa (5100 psi)
- TEMPERATURA MASSIMA MAX WORKING TEMPERATURE	90° C (195° F)
- MATERIALE MATERIAL	INOX AISI 303 (STAINLESS STEEL 303)

MISURE D'INGOMBRO - OVERALL DIMENSIONS

ST3 STURATUBO FISSI - 3 FORI
ST3 DRAIN CLEANING NOZZLE - 3 HOLES

ST4 STURATUBO FISSI - 4 FORI
ST4 DRAIN CLEANING NOZZLE - 4 HOLES

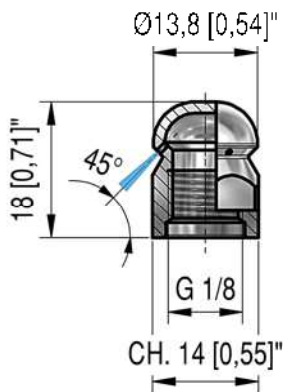

FP - SIZE	CODICE - P.N.
03	25.1203.30
04	25.1203.40
05	25.1203.50
06	25.1203.60
07	25.1203.70
08	25.1203.80

FP - SIZE	CODICE - P.N.
03	25.1204.30
04	25.1204.40
05	25.1204.50
06	25.1204.60
07	25.1204.70
08	25.1204.80

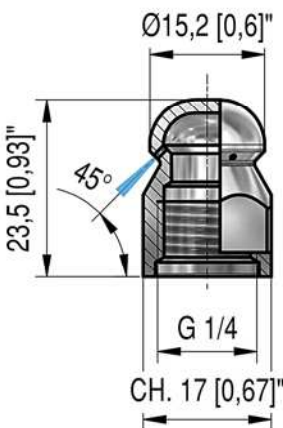
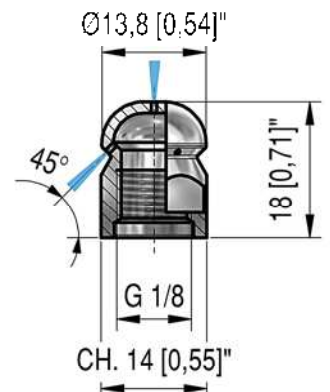

FP - SIZE	CODICE - P.N.
03	25.1213.30
04	25.1213.40
05	25.1213.50
06	25.1213.60
07	25.1213.70
08	25.1213.80

FP - SIZE	CODICE - P.N.
03	25.1214.30
04	25.1214.40
05	25.1214.50
06	25.1214.60
07	25.1214.70
08	25.1214.80

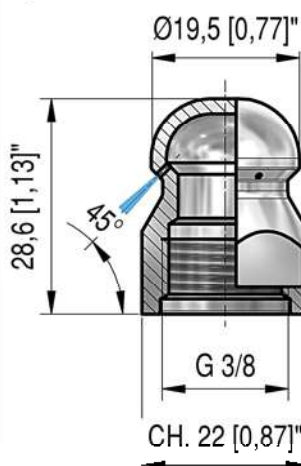
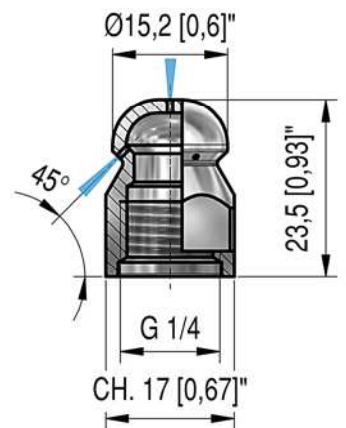

FP - SIZE	CODICE - P.N.
03	25.1223.30
04	25.1223.40
05	25.1223.50
06	25.1223.60
07	25.1223.70
08	25.1223.80

FP - SIZE	CODICE - P.N.
03	25.1224.30
04	25.1224.40
05	25.1224.50
06	25.1224.60
07	25.1224.70
08	25.1224.80

