



E QUIPAGGIAMENTI
T ECNICI
L AVAGGIO

21.0018.15
DOSATORE FISSO G3/8 M-M INOX D1.5
SST CHEMICAL INJECTOR 3/8 BSP MM

19/07/2016

CARATTERISTICHE TECNICHE - SPECIFICATIONS

- PRESSIONE NOMINALE RATED PRESSURE	350 bar - 35 MPa - 5100 psi
- PRESSIONE CONSENTITA PERMISSIBLE PRESSURE	390 bar - 39 MPa - 5650 psi
- PORTATA MASSIMA MAX FLOW RATE	30 l/min - 8 USGpm
- TEMPERATURA MASSIMA MAX WORKING TEMPERATURE	90 °C - 195 °F
- MATERIALI MATERIALS	ACCIAIO INOX E GUARNIZIONI IN TEFLON - STAINLESS STEEL AND SEALS IN TEFLON
- MASSA WEIGHT	125 gr - 4,41 oz

MISURE D'INGOMBRO - OVERALL DIMENSIONS

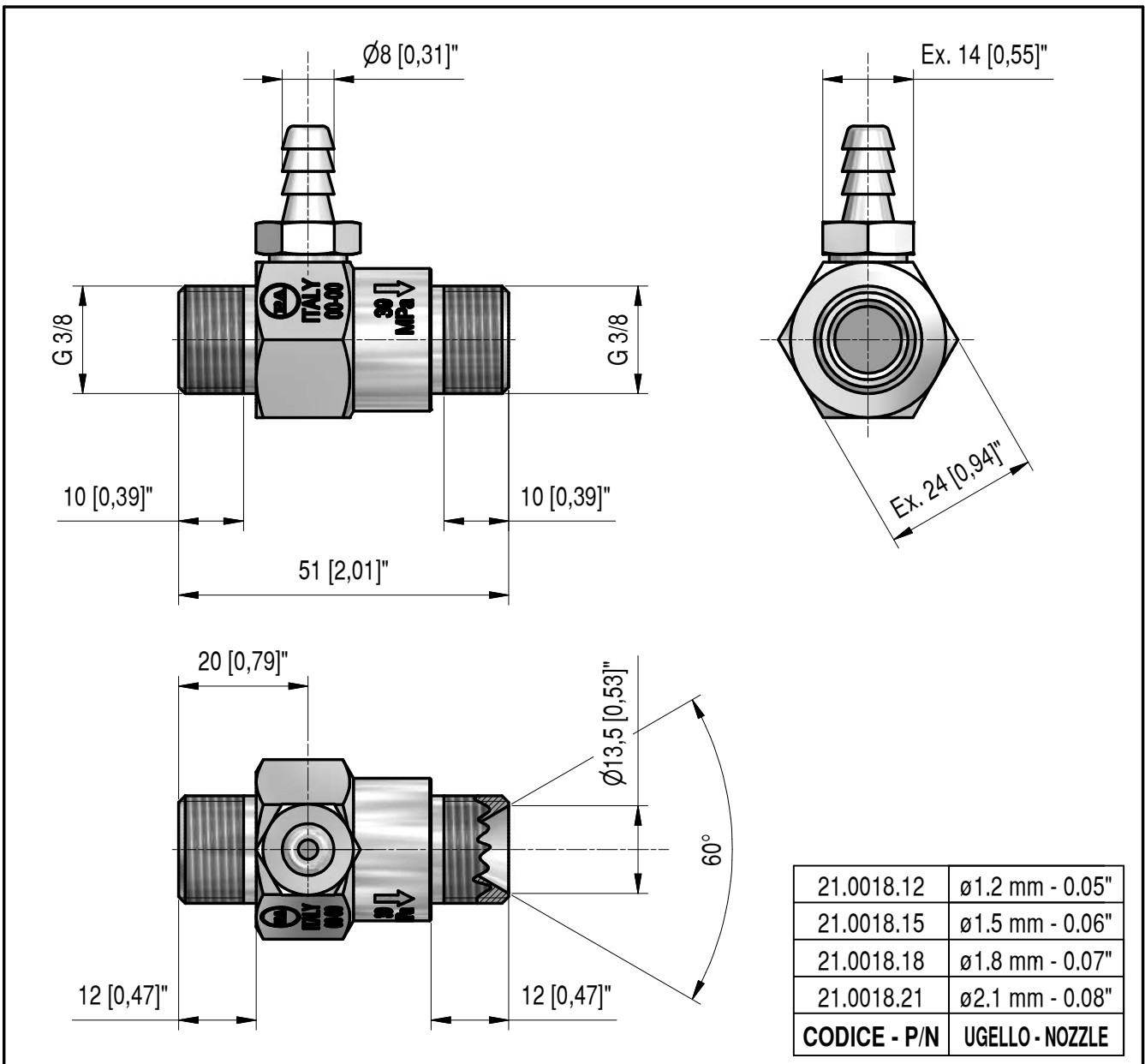



E QUIPAGGIAMENTI
T ECNICI
L AVAGGIO

21.0018.68
DOS FISSO 3/8NPT MM INOX D1.8
SST CHEMICAL INJECTOR 3/8NPT MM

19/07/2016

CARATTERISTICHE TECNICHE - SPECIFICATIONS

- PRESSIONE NOMINALE RATED PRESSURE	350 bar - 35 MPa - 5100 psi
- PRESSIONE CONSENTITA PERMISSIBLE PRESSURE	390 bar - 39 MPa - 5650 psi
- PORTATA MASSIMA MAX FLOW RATE	30 l/min - 8 USGpm
- TEMPERATURA MASSIMA MAX WORKING TEMPERATURE	90 °C - 195 °F
- MATERIALI MATERIALS	ACCIAIO INOX E GUARNIZIONI IN TEFLON - STAINLESS STEEL AND SEALS IN TEFLON
- MASSA WEIGHT	125 gr - 4,41 oz

MISURE D'INGOMBRO - OVERALL DIMENSIONS

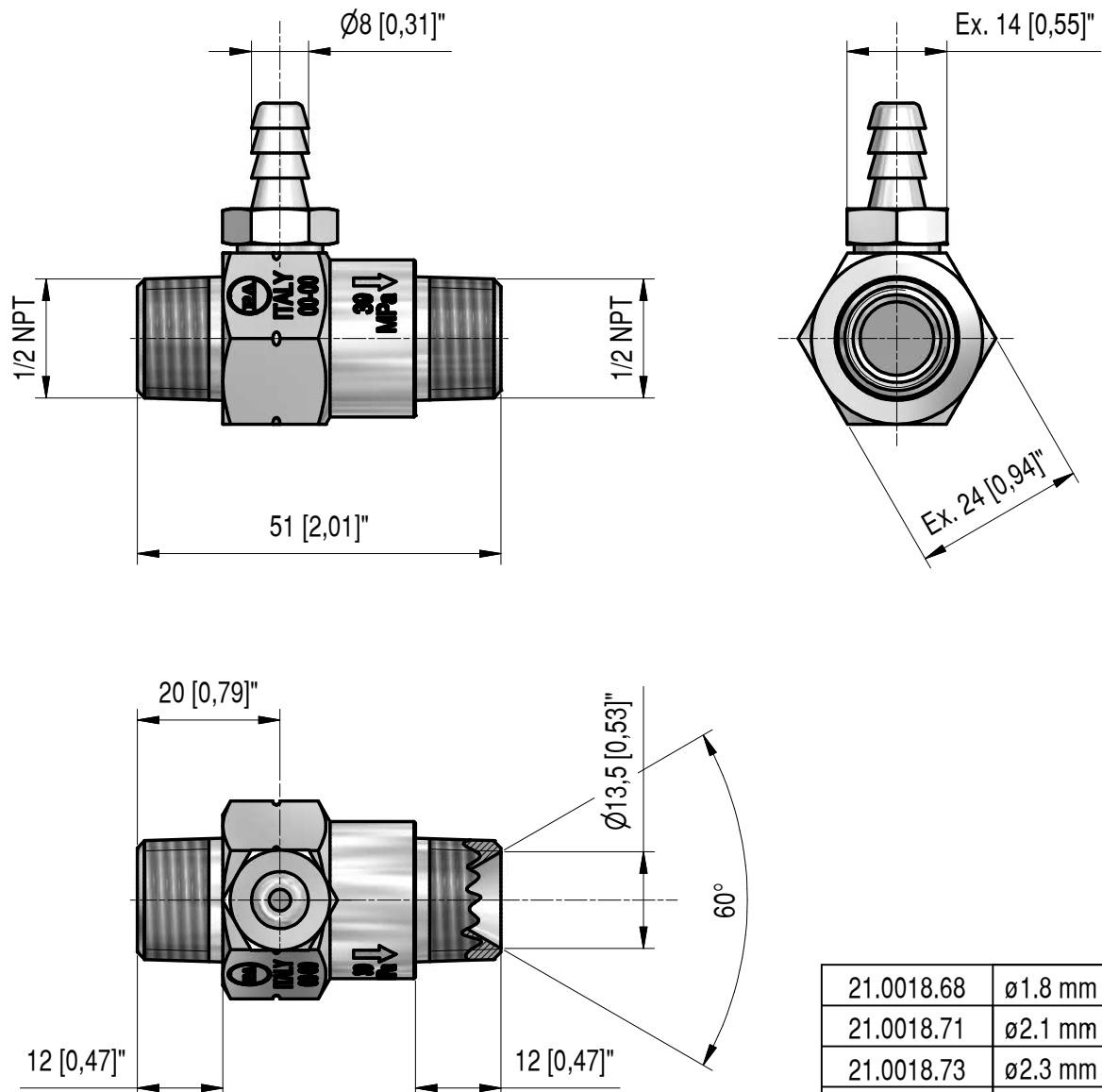

21.0018.68	$\varnothing 1.8$ mm - 0.07"
21.0018.71	$\varnothing 2.1$ mm - 0.08"
21.0018.73	$\varnothing 2.3$ mm - 0.09"
CODICE - P/N	UGELLO - NOZZLE



EQUIPAGGIAMENTI
TECNICI
LAVAGGIO

21.0119.15
DOS REG G3/8 MM INOX D1.5
SST CHEMICAL INJECTOR 3/8 BSP MM

19/07/2016

CARATTERISTICHE TECNICHE - SPECIFICATIONS

- PRESSIONE NOMINALE RATED PRESSURE	350 bar - 35 MPa - 5100 psi
- PRESSIONE CONSENTITA PERMISSIBLE PRESSURE	390 bar - 39 MPa - 5650 psi
- PORTATA MASSIMA MAX FLOW RATE	30 l/min - 8 USGpm
- TEMPERATURA MASSIMA MAX WORKING TEMPERATURE	90 °C - 195 °F
- MATERIALI MATERIALS	ACCIAIO INOX E GUARNIZIONI IN TEFLON - STAINLESS STEEL AND SEALS IN TEFLON
- MASSA WEIGHT	125 gr - 4,41 oz

MISURE D'INGOMBRO - OVERALL DIMENSIONS

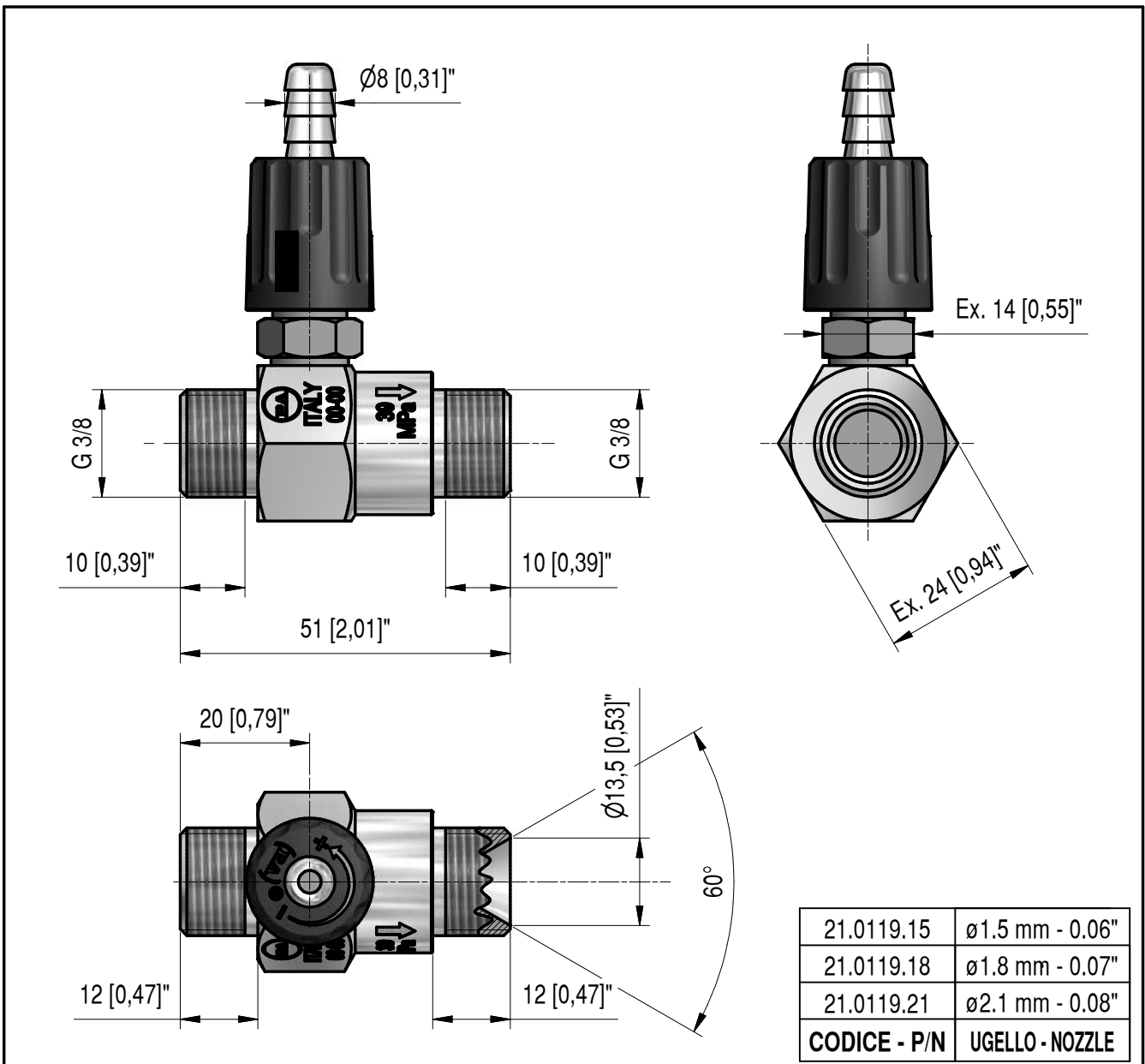



E QUIPAGGIAMENTI
T ECNICI
L AVAGGIO

21.0120.18
DOS REG 3/8NPT MM INOX D1.8
SST CHEMICAL INJECTOR 3/8NPT MM

19/07/2016

CARATTERISTICHE TECNICHE - SPECIFICATIONS

- PRESSIONE NOMINALE RATED PRESSURE	350 bar - 35 MPa - 5100 psi
- PRESSIONE CONSENTITA PERMISSIBLE PRESSURE	390 bar - 39 MPa - 5650 psi
- PORTATA MASSIMA MAX FLOW RATE	30 l/min - 8 USGpm
- TEMPERATURA MASSIMA MAX WORKING TEMPERATURE	90 °C - 195 °F
- MATERIALI MATERIALS	ACCIAIO INOX E GUARNIZIONI IN TEFLON - STAINLESS STEEL AND SEALS IN TEFLON
- MASSA WEIGHT	125 gr - 4,41 oz

MISURE D'INGOMBRO - OVERALL DIMENSIONS

